

Control (of death) - Demo Project

FilmProCaS by:

Date Shot

Arpad Zsolt Varga

Music Copyright by © T-34 Hungarian
Music Band - IHDS

Producer: Arpad Zsolt Varga

Co-producer: Szabolcs Juhasz

Copyright © 2022 Arpad Zsolt
Varga

All Right Reserved!

Copyright © 2024 Date Shot
Copyright by © Arpad Zsolt Varga
& Szabolcs Juhasz 201
Contact: filmprocas@gmail.com
imagehdstudio@gmail.com
www.imagehdstudio.com

Final Draft
7/31/2024

Scene: Harley Davidson shop and the parking place		Shooting Date: 8/9/2024
Shooting Place: City Harley Davidson Shop, Freedom street, Hódmezővásárhely		Shooting Day: 1
Format: 2.39:1 Mode	Frame rate: 30P	Film Rating: ASA 200
Camera: SONY V1U	T-Stop: 5.6 Gain: 0 dB	Kelvin/Mired: 5600 /178.6
Lens: ZEISS DigiZoom Lenses 17-112mm T1.9	Shutter: 180 1/60	Studio Interior Exterior
Filter: No.	Focus: 7 meter	Dawn Day Dusk Night
Film Stock: 16:9 Mode HD	Camera Move: Slow zoom in	

Picture text:

PICTURE 1

Fade in!

Exterior – in front of Motorcycle shop - Afternoon

In front of a Harley Davidson motorcycle shop stands the camera, in front of the store on their stands - four beautiful engines. Slow start zooming ahead.

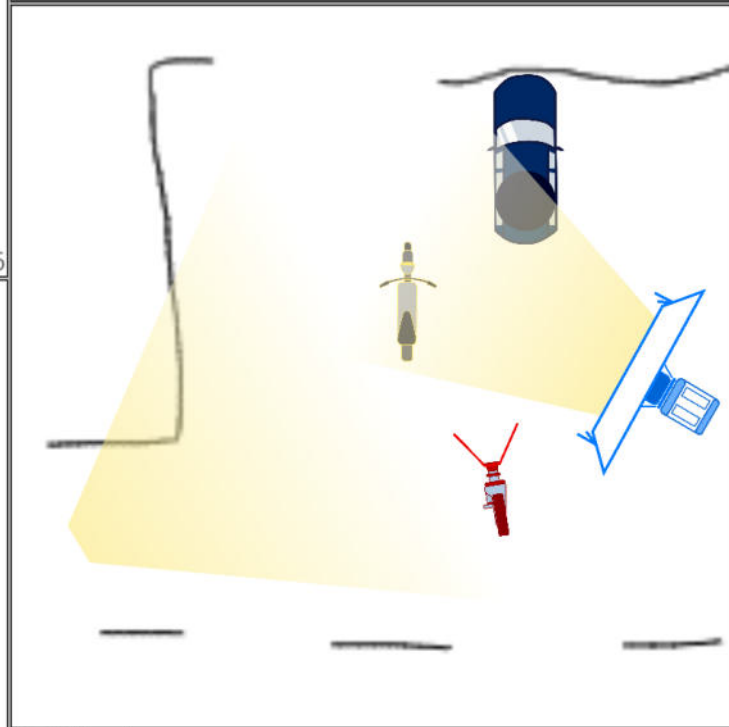

276

Sound/Dialog:

Sound: MUSIC

+ Motorcycle sound effect

Light Used:
 Lighting set;
 2x Arri Spot 500 W
 2 X Arri Spot 800 W
 2 X Arri Spot 1000 W
 2 X Arri Spot 2000 W
 Led Panel
 KinoFlo
 Soft box
 Lee lighting filter yellow and green
 Camera Tripod

91

Cast:

0

173

Notes: Renting at the Harley Davidson Shop for the duration of the shoot

67

Scene: Harley Davidson shop

Shooting Date:

8/9/2024

Shooting Place: City Harley Davidson Shop, Freedom street, Hódmezővásárhely

Shooting Day:

1

Format: 2.39:1 Mode

Frame rate: 30P

Film Rating: ASA 200

Camera: SONY V1U

T-Stop: 4 Gain: 0 dB

Kelvin/Mired: 3200 /312.5

Lens: ZEISS DigiZoom Lenses 17-112mm T1.9

Shutter: 180 1/60

Studio Interior Exterior

Filter: No.

Focus: 2 meter

Dawn Day Dusk Night

Film Stock: 16:9 Mode HD

Camera Move: Camera static



Picture text:

PICTURE 2

Interior – Harley Shop - Afternoon

Someone throws a wad of cash on the table, the camera is over the table, taking a close-up as the stack of cash falls into the picture.



236

Sound/Dialog:

Sound: MUSIC

+ Motorcycle sound effect

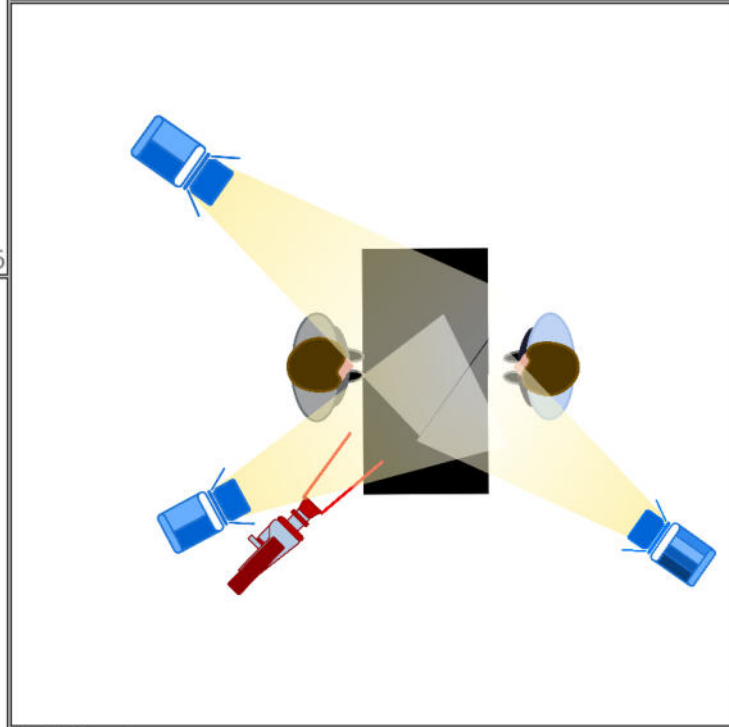

Light Used:

Lighting set;

2x Arri Spot 500 W

2 X Arri Spot 800 W

2 X Arri Spot 1000 W

2 X Arri Spot 2000 W

Led Panel

KinoFlo

Soft box

Lee lighting filter yellow and green

Camera Tripod

91

Cast: Szabolcs Juhasz, Seller: Attila Konyecnyi

42

173

Notes: Renting at the Harley Davidson Shop for the duration of the shoot

65

Scene: Harley Davidson shop		Shooting Date: 8/9/2024
Shooting Place: City Harley Davidson Shop, Freedom street, Hódmezővásárhely		Shooting Day: 1
Format: 2.39:1 Mode	Frame rate: 30P	Film Rating: ASA 200
Camera: SONY V1U	T-Stop: 4 Gain: 0 dB	Kelvin/Mired: 3200 /312.5
Lens: ZEISS DigiZoom Lenses 17-112mm T1.9	Shutter: 180 1/60	Studio Interior Exterior
Filter: No.	Focus: 2 meter	Dawn Day Dusk Night
Film Stock: 16:9 Mode HD	Camera Move: Camera static	

Picture text:

PICTURE 3

Interior - Harley Shop - Afternoon

A hand renders a Harley key – camera in closeup -- from behind the counter, then another hand takes over, -- camera in closeup –takes the money from the counter and pulls his hand out of the picture.

299

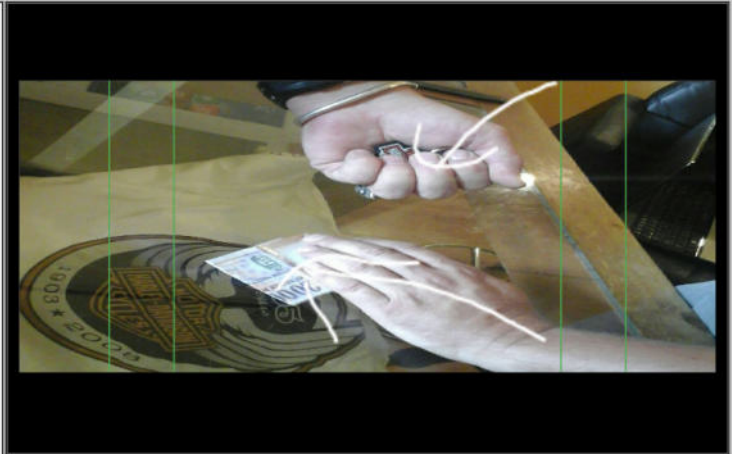

Sound/Dialog:

Sound: MUSIC

+ Motorcycle sound effect

91

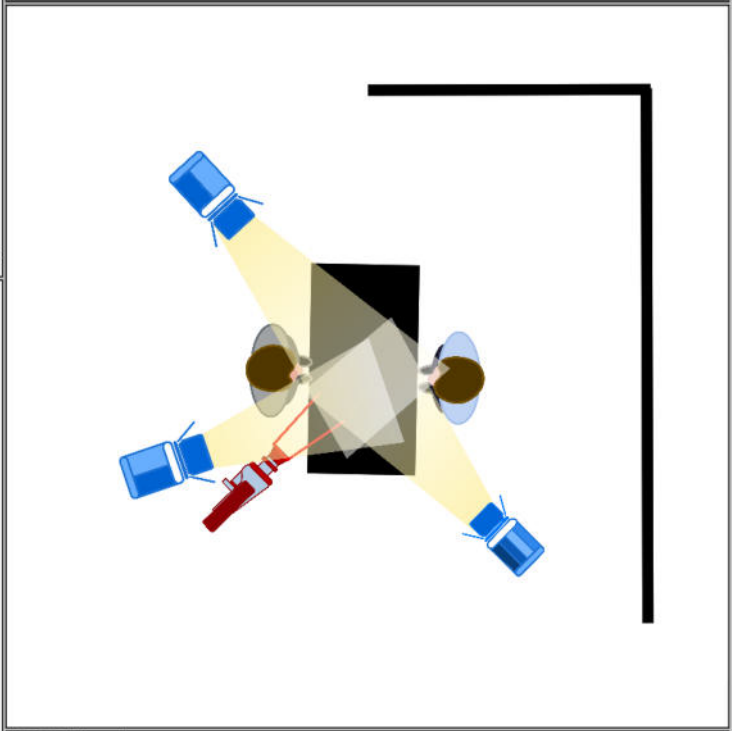

Light Used:
 Lighting set;
 2x Arri Spot 500 W
 2 X Arri Spot 800 W
 2 X Arri Spot 1000 W
 2 X Arri Spot 2000 W
 Led Panel
 KinoFlo
 Soft box
 Lee lighting filter yellow and green
 Camera Tripod

173

Cast: Szabolcs Juhasz, Seller: Attila Konyecsnyi

42

Notes: Renting at the Harley Davidson Shop for the duration of the shoot.

66

Scene: Harley Davidson shop

Shooting Date:

8/9/2024

Shooting Place: City Harley Davidson Shop, Freedom street, Hódmezővásárhely

Shooting Day:

1

Format: 2.39:1 Mode

Frame rate: 30P

Film Rating: ASA 200

Camera: SONY V1U

T-Stop: 4 Gain: 0 dB

Kelvin/Mired: 3200 /312.5

Lens: ZEISS DigiZoom Lenses 17-112mm T1.9

Shutter: 180 1/60

Studio Interior Exterior

Filter: No.

Focus: 2.5 meter

Dawn Day Dusk Night

Film Stock: 16:9 Mode HD

Camera Move: Camera static

Picture text:

PICTURE 4

Interior – Harley Shop - Afternoon

The shopkeeper's face as he looks pleased after the man – in premiere plan, close-up.

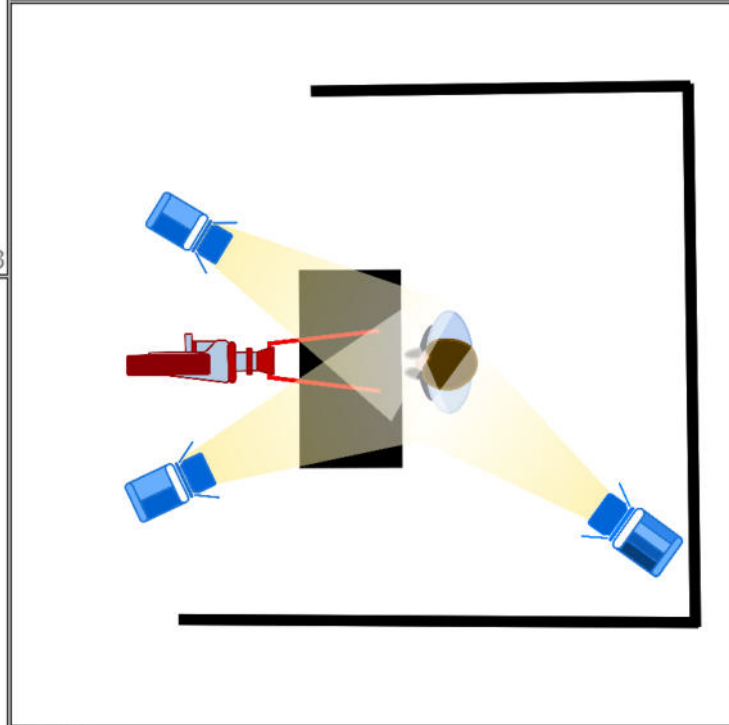

183

Sound/Dialog:

Sound: MUSIC

+ Motorcycle sound effect

Light Used:
 Lighting set;
 2x Arri Spot 500 W
 2 X Arri Spot 800 W
 2 X Arri Spot 1000 W
 2 X Arri Spot 2000 W
 Led Panel
 KinoFlo
 Soft box
 Lee lighting filter yellow and green
 Camera Tripod

91

Cast: Szabolcs Juhasz, Seller: Attila Konyecsnyi

43

173

Notes: Renting at the Harley Davidson Shop for the duration of the shoot.

66

Scene: Harley Davidson shop		Shooting Date: 8/9/2024
Shooting Place: City Harley Davidson Shop, Freedom street, Hódmezővásárhely		Shooting Day: 1
Format: 2.39:1 Mode	Frame rate: 30P	Film Rating: ASA 200
Camera: SONY V1U	T-Stop: 4 Gain: 0 dB	Kelvin/Mired: 3200 /312.5
Lens: ZEISS DigiZoom Lenses 17-112mm T1.9	Shutter: 180 1/60	Studio Interior Exterior
Filter: No.	Focus: 4 meter	Dawn Day Dusk Night
Film Stock: 16:9 Mode HD	Camera Move: Camera static 	

Picture text:

PICTURE 5

Interior - Harley Shop - Afternoon

The camera shows the side-view of the rider who, starting from the counter toward the exit, the camera in left-panorama, follows him a while until the Harleys available in the store come into the picture.



302

Sound/Dialog:

Sound: MUSIC
+ Motorcycle sound effect

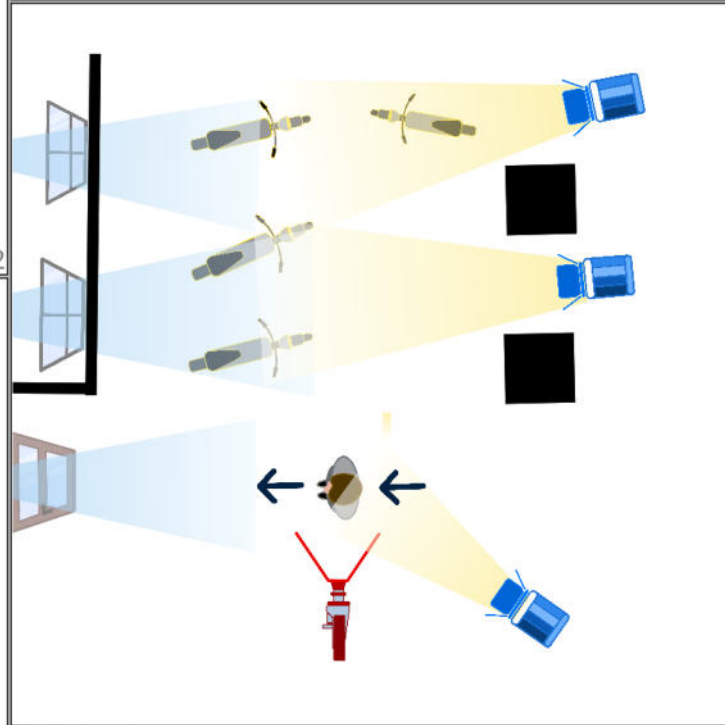

Light Used:
Lighting set;
2x Arri Spot 500 W
2 X Arri Spot 800 W
2 X Arri Spot 1000 W
2 X Arri Spot 2000 W
Led Panel
KinoFlo
Soft box
Lee lighting filter yellow and green
Camera Tripod

91

Cast: Szabolcs Juhasz, Seller: Attila Konyecsnyi

42

173

Notes: Renting at the Harley Davidson Shop for the duration of the shoot.

67

Scene: Harley Davidson shop		Shooting Date: 8/9/2024
Shooting Place: City Harley Davidson Shop, Freedom street, Hódmezővásárhely		Shooting Day: 1
Format: 2.39:1 Mode	Frame rate: 30P	Film Rating: ASA 200
Camera: SONY V1U	T-Stop: 4 Gain: 0 dB	Kelvin/Mired: 3200 /312.5
Lens: ZEISS DigiZoom Lenses 17-112mm T1.9	Shutter: 180 1/60	Studio Interior Exterior
Filter: No.	Focus: 4 meter	Dawn Day Dusk Night
Film Stock: 16:9 Mode HD	Camera Move: Camera static	

Picture text:

PICTURE 6

Interior - Harley Shop - Afternoon

The door closes behind the man leaving in riders garb, we do not see the man's face, he is with his back to you. Only the door closes behind him.

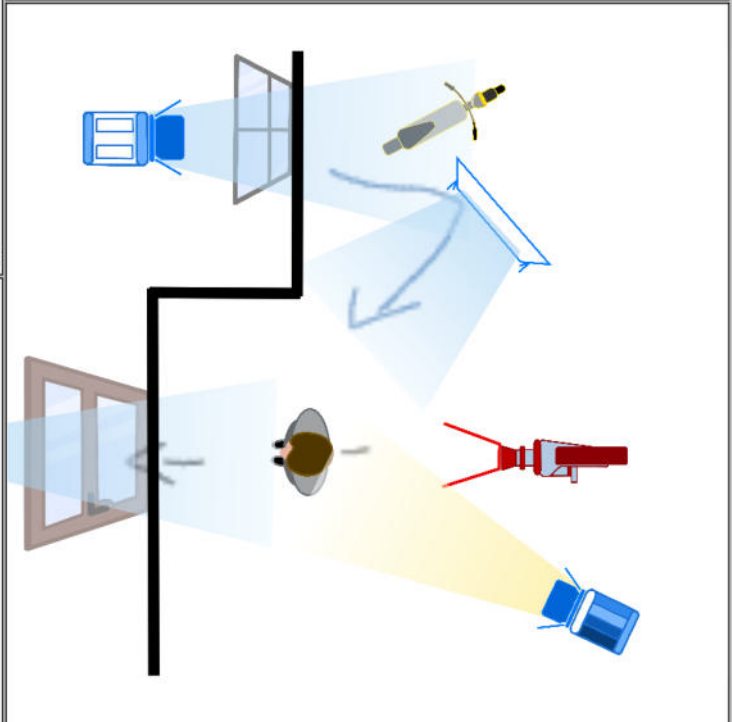
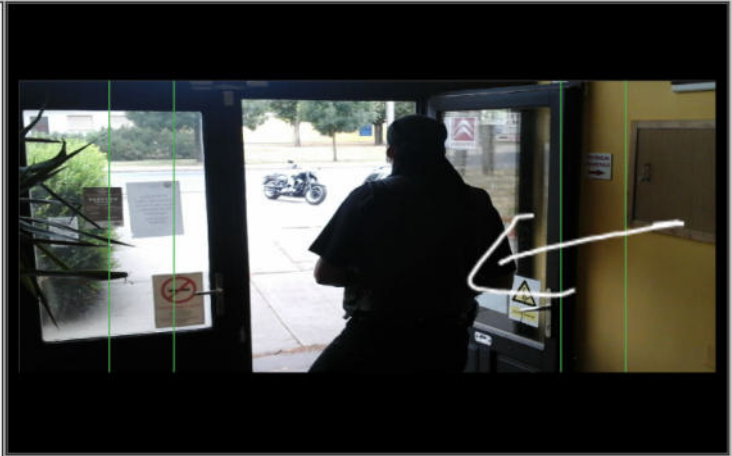

Sound/Dialog:

Sound: MUSIC

+ Motorcycle sound effect

Light Used:
 Lighting set;
 2x Arri Spot 500 W
 2 X Arri Spot 800 W
 2 X Arri Spot 1000 W
 2 X Arri Spot 2000 W
 Led Panel
 KinoFlo
 Soft box
 Lee lighting filter yellow and green
 Camera Tripod

Cast: Szabolcs Juhasz, Seller: Attila Konyecsnyi

Notes: Renting at the Harley Davidson Shop for the duration of the shoot

Scene: Harley Davidson shop and the parking place

Shooting Date:

8/9/2024

Shooting Place: Harley Davidson Shop parking place, Freedom st. Hódmezővásárhely

Shooting Day:

1

Format: 2.39:1 Mode

Frame rate: 30P

Film Rating: ASA 200

Camera: SONY V1U

T-Stop: 5.6 Gain: 0 dB

Kelvin/Mired: 5600 /178.6

Lens: ZEISS DigiZoom Lenses 17-112mm T1.9

Shutter: 180 1/60

Studio Interior **Exterior**

Filter: No.

Focus: 1.5 meter

Dawn **Day** Dusk Night

Film Stock: 16:9 Mode HD

Camera Move: Camera static

Picture text:

PICTURE 7

Exterior - before Motorcycle shop - Afternoon

The camera shows the other side of the engine as two motorcycle boots come into the picture and stop. The rider stopped next to the chosen motorcycle.



254

Sound/Dialog:

Sound: MUSIC

+ Motorcycle sound effect

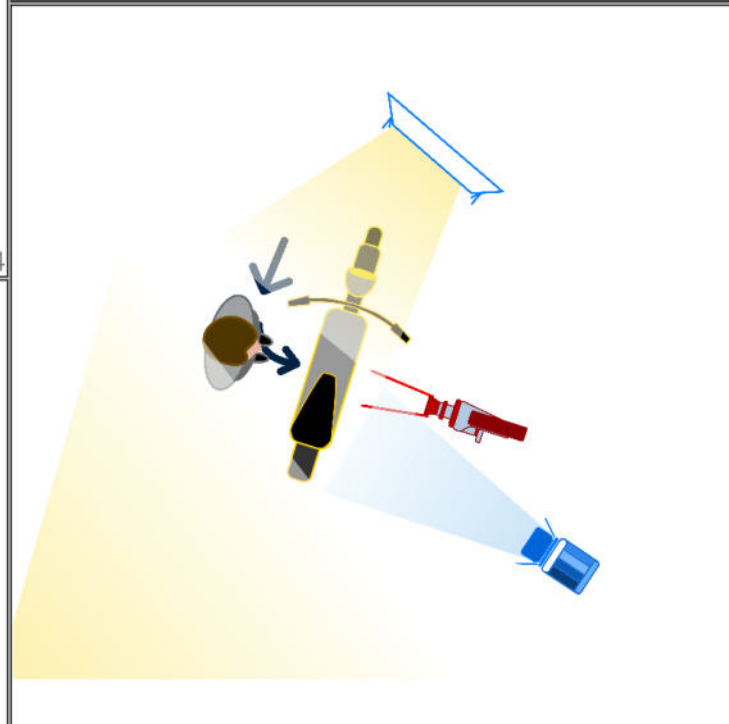

Light Used:

Lighting set;

2x Arri Spot 500 W

2 X Arri Spot 800 W

2 X Arri Spot 1000 W

2 X Arri Spot 2000 W

Led Panel

KinoFlo

Soft box

Lee lighting filter yellow and green

Camera Tripod

91

Cast: Szabolcs Juhasz

16

173

Notes: Renting at the Harley Davidson Shop for the duration of the shoot

66

Scene: Harley Davidson shop and the parking place		Shooting Date: 8/9/2024
Shooting Place: Harley Davidson Shop parking place, Freedom st. Hódmezővásárhely		Shooting Day: 1
Format: 2.39:1 Mode	Frame rate: 30P	Film Rating: ASA 200
Camera: SONY V1U	T-Stop: 5.6 Gain: 0 dB	Kelvin/Mired: 5600 /178.6
Lens: ZEISS DigiZoom Lenses 17-112mm T1.9	Shutter: 180 1/60	Studio Interior Exterior
Filter: No.	Focus: 4.5 meter	Dawn Day Dusk Night
Film Stock: 16:9 Mode HD	Camera Move: Camera static 	

Picture text:

PICTURE 8

Exterior - before Motorcycle shop - Afternoon

The camera is opposite the shop behind the motorcycle as JSZ getson the Harley motorcycle. Little Total Plan.

217

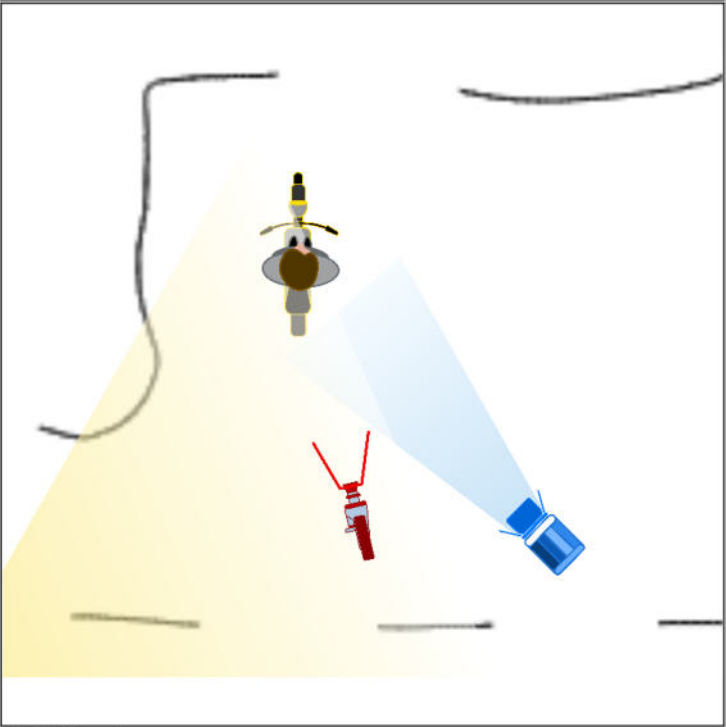

Sound/Dialog:

Sound: MUSIC

+ Motorcycle sound effect

91

Light Used:
 Lighting set;
 2x Arri Spot 500 W
 2 X Arri Spot 800 W
 2 X Arri Spot 1000 W
 2 X Arri Spot 2000 W
 Led Panel
 KinoFlo
 Soft box
 Lee lighting filter yellow and green
 Camera Tripod

Cast: Szabolcs Juhasz

16

173

Notes: Renting at the Harley Davidson Shop for the duration of the shoot

66

Scene: Harley Davidson shop and the parking place		Shooting Date: 8/9/2024
Shooting Place: Harley Davidson Shop parking place, Freedom st. Hódmezővásárhely		Shooting Day: 1
Format: 2.39:1 Mode	Frame rate: 30P	Film Rating: ASA 200
Camera: SONY V1U	T-Stop: 5.6 Gain: 0 dB	Kelvin/Mired: 5600 /178.6
Lens: ZEISS DigiZoom Lenses 17-112mm T1.9	Shutter: 180 1/60	Studio Interior Exterior
Filter: No.	Focus: 1 meter	Dawn Day Dusk Night
Film Stock: 16:9 Mode HD	Camera Move: Camera static	

Picture text:

PICTURE 9

Exterior - before Motorcycle shop - Afternoon

Close up of Hand as the key is inserted into the ignition of the Harley.

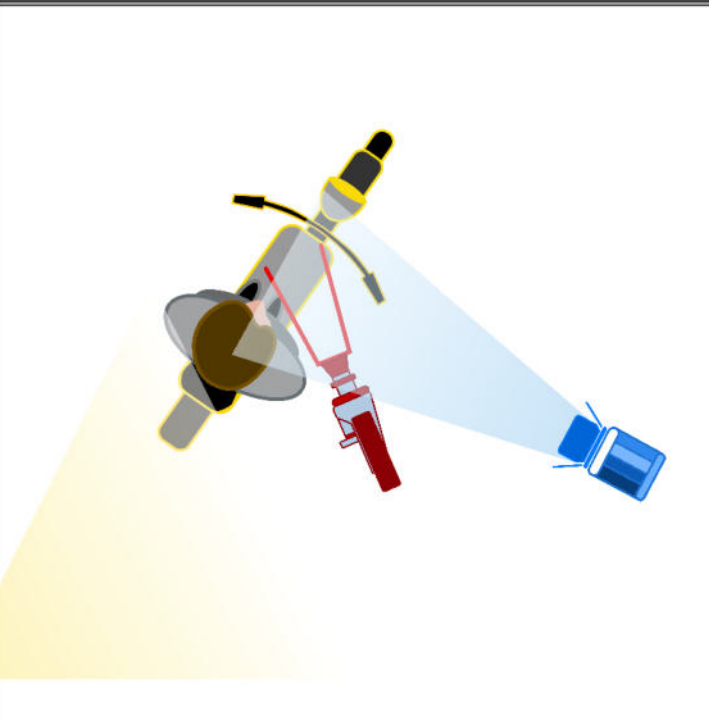

Sound/Dialog:

Sound: MUSIC

+ Motorcycle sound effect

Light Used:
 Lighting set;
 2x Arri Spot 500 W
 2 X Arri Spot 800 W
 2 X Arri Spot 1000 W
 2 X Arri Spot 2000 W
 Led Panel
 KinoFlo
 Soft box
 Lee lighting filter yellow and green
 Camera Tripod

Cast: Szabolcs Juhasz

Notes: Renting at the Harley Davidson Shop for the duration of the shoot

Scene: Harley Davidson shop and the parking place		Shooting Date: 8/9/2024
Shooting Place: Harley Davidson Shop parking place, Freedom st. Hódmezővásárhely		Shooting Day: 1
Format: 2.39:1 Mode	Frame rate: 30P	Film Rating: ASA 200
Camera: SONY V1U	T-Stop: 5.6 Gain: 0 dB	Kelvin/Mired: 5600 /178.6
Lens: ZEISS DigiZoom Lenses 17-112mm T1.9	Shutter: 180 1/60	Studio Interior Exterior
Filter: No.	Focus: 1 meter	Dawn Day Dusk Night
Film Stock: 16:9 Mode HD	Camera Move: Camera static	

Picture text:

PICTURES 10

Exterior - before Motorcycle shop - Afternoon

Hand-close Close-up, as gripping the steering and throttle to start the engine.

190



Sound/Dialog:

Sound: MUSIC

+ Motorcycle sound effect

91

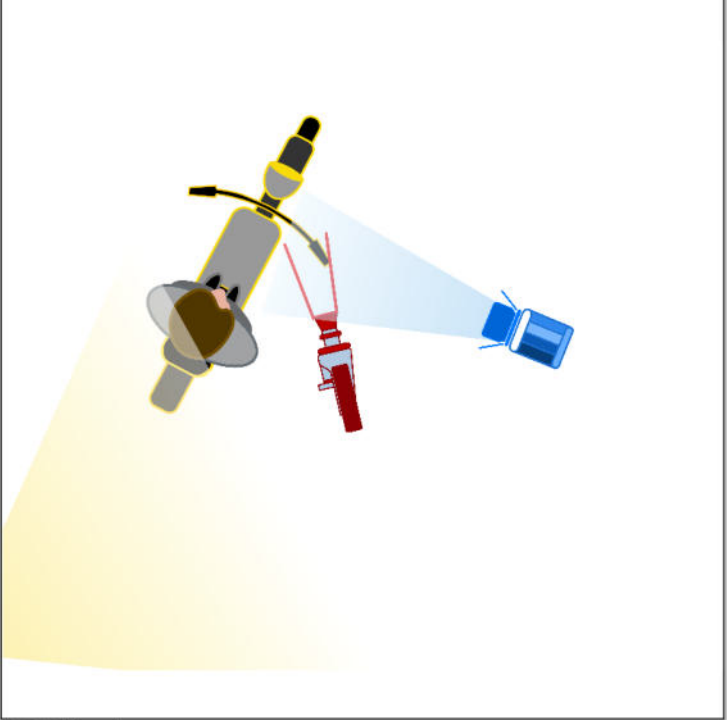

Light Used:
 Lighting set;
 2x Arri Spot 500 W
 2 X Arri Spot 800 W
 2 X Arri Spot 1000 W
 2 X Arri Spot 2000 W
 Led Panel
 KinoFlo
 Soft box
 Lee lighting filter yellow and green
 Camera Tripod

173

Cast: Szabolcs Juhasz

16

Notes: Renting at the Harley Davidson Shop for the duration of the shoot

66

Scene: Harley Davidson shop and the parking place		Shooting Date: 8/9/2024
Shooting Place: Harley Davidson Shop parking place, Freedom st. Hódmezővásárhely		Shooting Day: 1
Format: 2.39:1 Mode	Frame rate: 30P	Film Rating: ASA 200
Camera: SONY V1U	T-Stop: 5.6 Gain: 0 dB	Kelvin/Mired: 5600 /178.6
Lens: ZEISS DigiZoom Lenses 17-112mm T1.9	Shutter: 180 1/60	Studio Interior Exterior
Filter: No.	Focus: 1 meter	Dawn Day Dusk Night
Film Stock: 16:9 Mode HD	Camera Move: Camera static	

Picture text:

PICTURES 11

Exterior - before Motorcycle shop - Afternoon

Close-up of the exhaust-pipes with the sound of the engine starting.

181

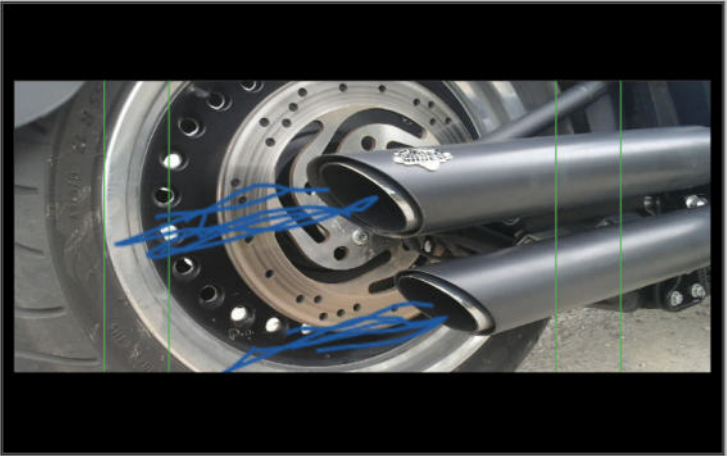

Sound/Dialog:

Sound: MUSIC

+ Motorcycle sound effect

91

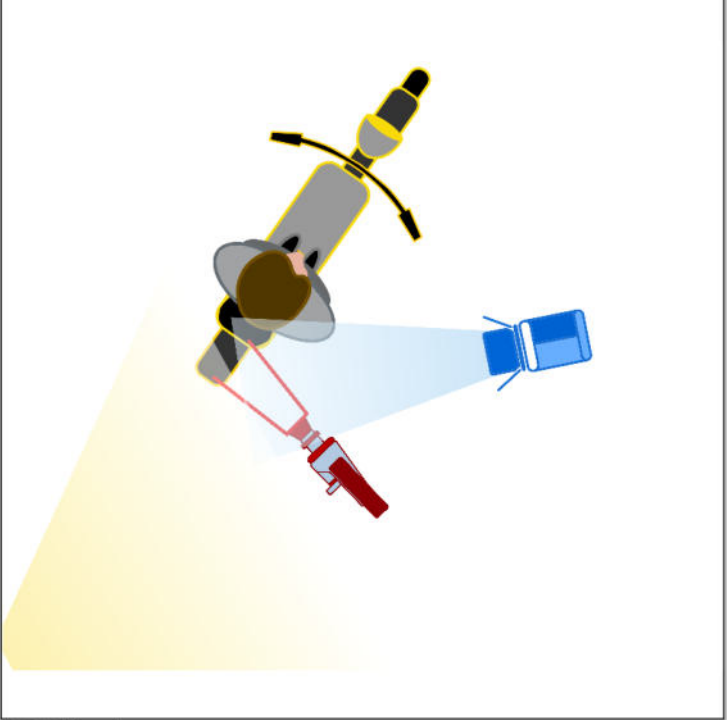

Light Used:
 Lighting set;
 2x Arri Spot 500 W
 2 X Arri Spot 800 W
 2 X Arri Spot 1000 W
 2 X Arri Spot 2000 W
 Led Panel
 KinoFlo
 Soft box
 Lee lighting filter yellow and green
 Camera Tripod

173

Cast: Szabolcs Juhasz

16

Notes: Renting at the Harley Davidson Shop for the duration of the shoot

66

Scene: Harley Davidson shop and the parking place		Shooting Date: 8/9/2024
Shooting Place: Harley Davidson Shop parking place, Freedom st. Hódmezővásárhely		Shooting Day: 1
Format: 2.39:1 Mode	Frame rate: 30P	Film Rating: ASA 200
Camera: SONY V1U	T-Stop: 5.6 Gain: 0 dB	Kelvin/Mired: 5600 /178.6
Lens: ZEISS DigiZoom Lenses 17-112mm T1.9	Shutter: 180 1/60	Studio Interior Exterior
Filter: No.	Focus: 8 meter	Dawn Day Dusk Night
Film Stock: 16:9 Mode HD	Camera Move: Fix and follows actor move	

Picture text:

PICTURES 12

Exterior - before Motorcycle shop - Afternoon

The camera opposite the shop -- medium Total Plan -- shows as the motorist starts, turning to the left. The camera follows panorama. The motorists face is not visible, he just drives off onto the road and away.



314

Sound/Dialog:

Sound: MUSIC
+ Motorcycle sound effect

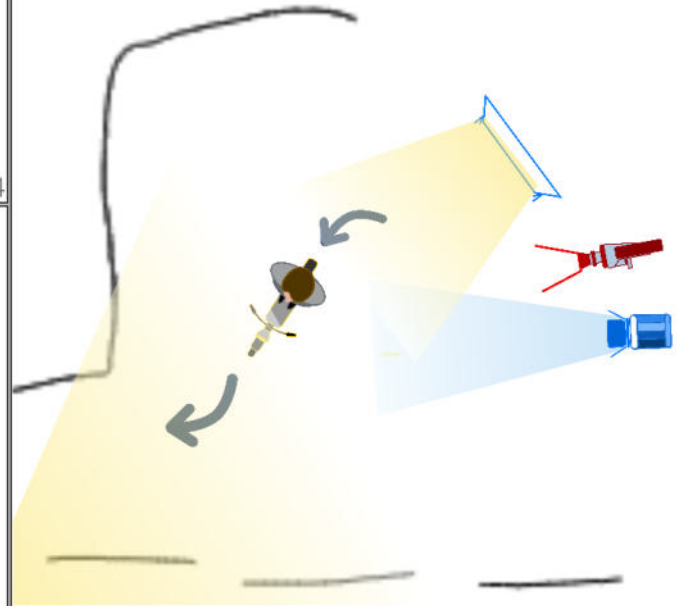

Light Used:
Lighting set;
2x Arri Spot 500 W
2 X Arri Spot 800 W
2 X Arri Spot 1000 W
2 X Arri Spot 2000 W
Led Panel
KinoFlo
Soft box
Lee lighting filter yellow and green
Camera Tripod

91

Cast: Szabolcs Juhasz

16

173

Notes: Renting at the Harley Davidson Shop for the duration of the shoot

66

Scene: One the road		Shooting Date: 8/10/2024
Shooting Place: Mártély City - road between all the Mindszent City.		Shooting Day: 2
Format: 2.39:1 Mode	Frame rate: 30P	Film Rating: ASA 200
Camera: SONY V1U	T-Stop: 5.6 Gain: 0 dB	Kelvin/Mired: 5600 /178.6
Lens: ZEISS DigiZoom Lenses 17-112mm T1.9	Shutter: 180 1/60	Studio Interior Exterior
Filter: No.	Focus: 0.30 meter	Dawn Day Dusk Night
Film Stock: 16:9 Mode HD	Camera Move: Fix camera shot and zoom in	

Picture text:

PICTURE 16

Exterior - Mindszenti road - Afternoon

The camera shows the Harley's speedometer on the right side with the skull and crossbones, as it goes up, reaching the 100 and going above and moving on...



255

Sound/Dialog:

Sound: MUSIC
+ Motorcycle sound effect

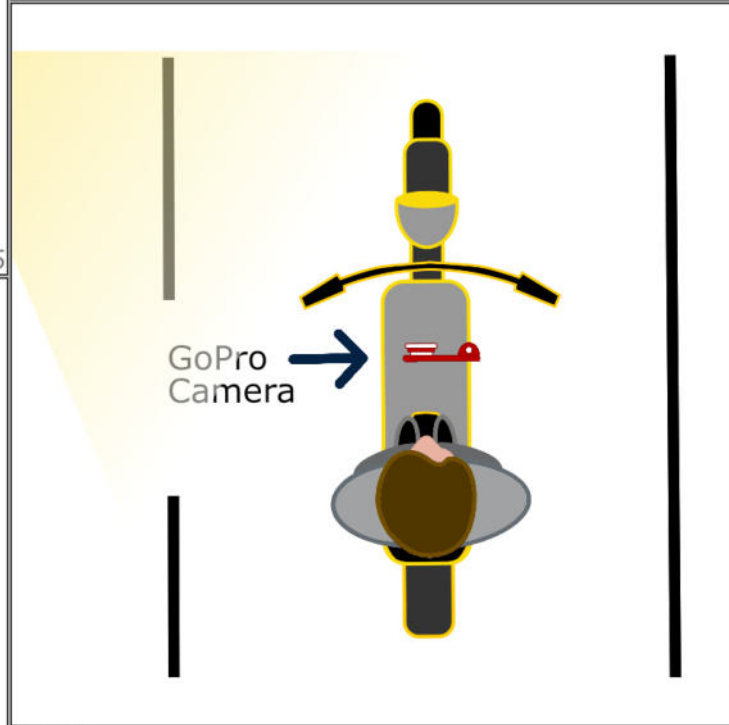

Light Used:
Lighting set;
2x Arri Spot 500 W
2 X Arri Spot 800 W
2 X Arri Spot 1000 W
2 X Arri Spot 2000 W
Led Panel
KinoFlo
Soft box
Lee lighting filter yellow and green
Camera Tripod

91

Cast: Szabolcs Juhasz

15

173

Notes: Requesting a police roadblock for the duration of the shoot

59

Scene: One the road		Shooting Date: 8/10/2024
Shooting Place: Mártéy City - road between all the Mindszent City.		Shooting Day: 2
Format: 2.39:1 Mode	Frame rate: 30P	Film Rating: ASA 200
Camera: SONY V1U	T-Stop: 5.6 Gain: 0 dB	Kelvin/Mired: 5600 /178.6
Lens: ZEISS DigiZoom Lenses 17-112mm T1.9	Shutter: 180 1/60	Studio Interior Exterior
Filter: No.	Focus: 1 meter	Dawn Day Dusk Night
Film Stock: 16:9 Mode HD	Camera Move: Camera stays fixed, motor move	

Picture text:

PICTURE 18

Exterior - Mindszenti road – Late afternoon

The camera, next to the moving Harley shows a sideview of the block, the camera-panorama moves quickly from the block to the rapidly rotating front wheel.

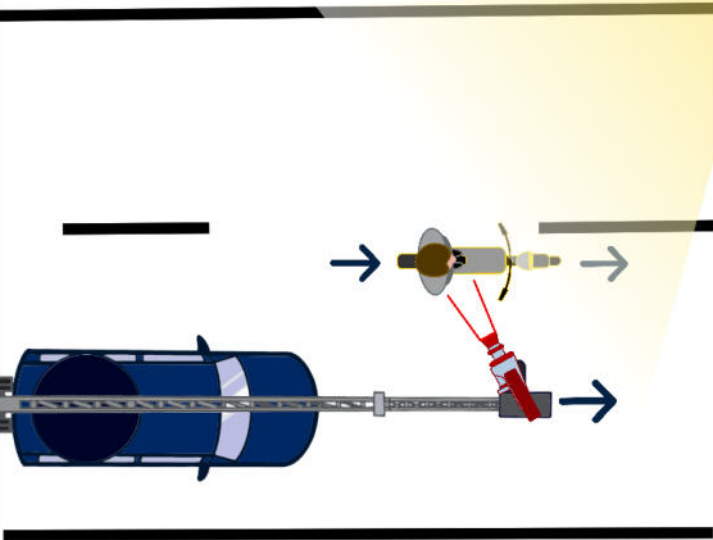

Sound/Dialog:

Sound: MUSIC

+ Motorcycle sound effect

Light Used:
 Lighting set;
 2x Arri Spot 500 W
 2 X Arri Spot 800 W
 2 X Arri Spot 1000 W
 2 X Arri Spot 2000 W
 Led Panel
 KinoFlo
 Soft box
 Lee lighting filter yellow and green
 Camera Tripod

Cast: Szabolcs Juhasz

Notes: Requesting a police roadblock for the duration of the shoot

Scene: On the way with the devil		Shooting Date: 8/10/2024
Shooting Place: Mártély City - road between all the Mindszent City.		Shooting Day: 2
Format: 2.39:1 Mode	Frame rate: 30P	Film Rating: ASA 200
Camera: SONY V1U	T-Stop: 2.8 Gain: 0 dB	Kelvin/Mired: 3200 /312.5
Lens: ZEISS DigiZoom Lenses 17-112mm T1.9	Shutter: 180 1/60	Studio Interior Exterior
Filter: No.	Focus: 2.5 meter	Dawn Day Dusk Night
Film Stock: 16:9 Mode HD	Camera Move: Camera static, and zoom in	

Picture text:

PICTURE 20

Exterior - Mindszenti road - Late afternoon

The camera in Total Plan, from in front of the rider -- shows as death with the scythe sits behind the rider -- enjoying the speed

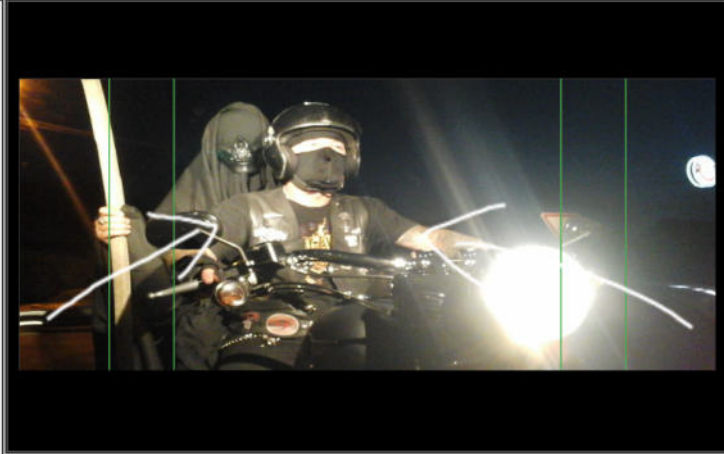

243

Sound/Dialog:

Sound: MUSIC
+ Motorcycle sound effect

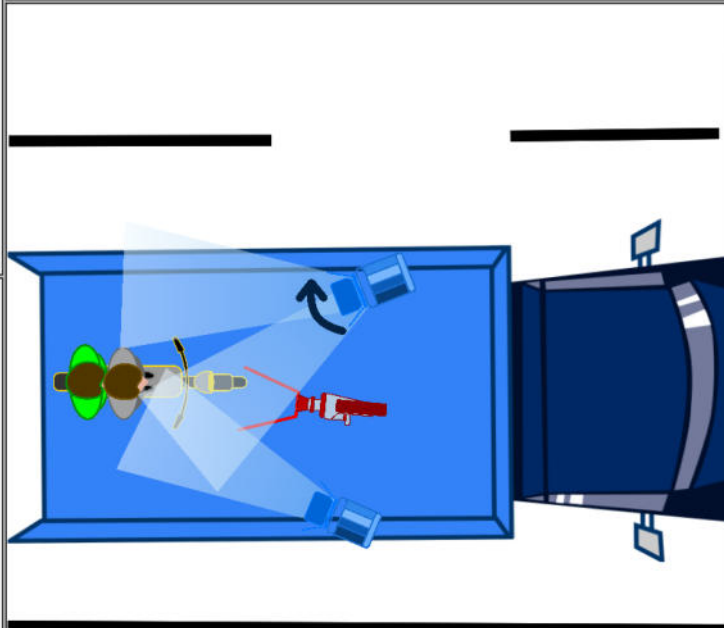

Light Used:
Lighting set;
2x Arri Spot 500 W
2 X Arri Spot 800 W
2 X Arri Spot 1000 W
2 X Arri Spot 2000 W
Led Panel
KinoFlo
Soft box
Lee lighting filter yellow and green
Camera Tripod

91

Cast: Szabolcs Juhasz, and death costume Gábor Kis

45

173

Notes: Requesting a police roadblock for the duration of the shoot

59

Scene: On the way with the devil		Shooting Date: 8/10/2024
Shooting Place: Mártély City - road between all the Mindszent City.		Shooting Day: 2
Format: 2.39:1 Mode	Frame rate: 30P	Film Rating: ASA 200
Camera: SONY V1U	T-Stop: 3.2 Gain: 0 dB	Kelvin/Mired: 2800 /357.1
Lens: ZEISS DigiZoom Lenses 17-112mm T1.9	Shutter: 180 1/60	Studio Interior Exterior
Filter: No.	Focus: 30 meter	Dawn Day Dusk Night
Film Stock: 16:9 Mode HD	Camera Move: Fix camera shot, telephoto	

Picture text:

PICTURE 22

Exterior - Mindszenti road – Late afternoon

The camera moving behind the engine, filming forward, as death is covering the rider from the image with his cloak and the great shroud.

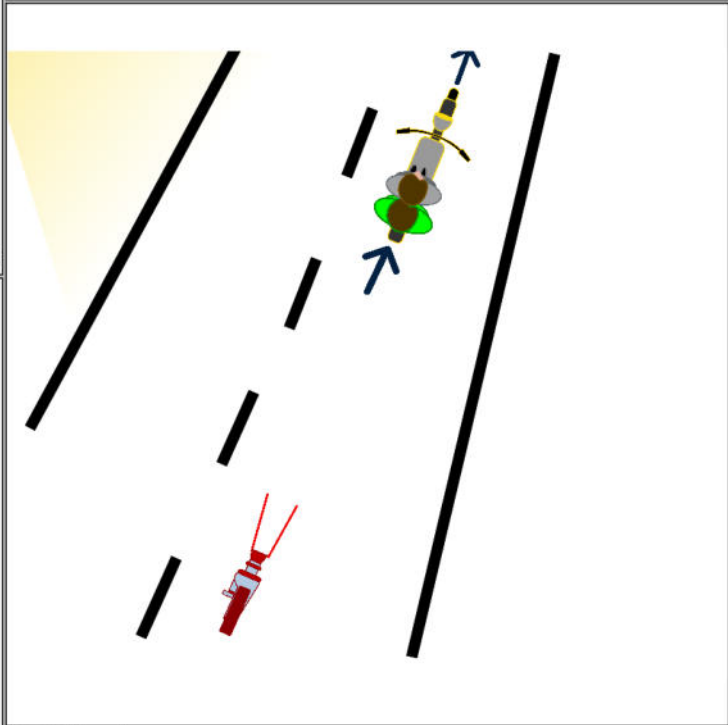
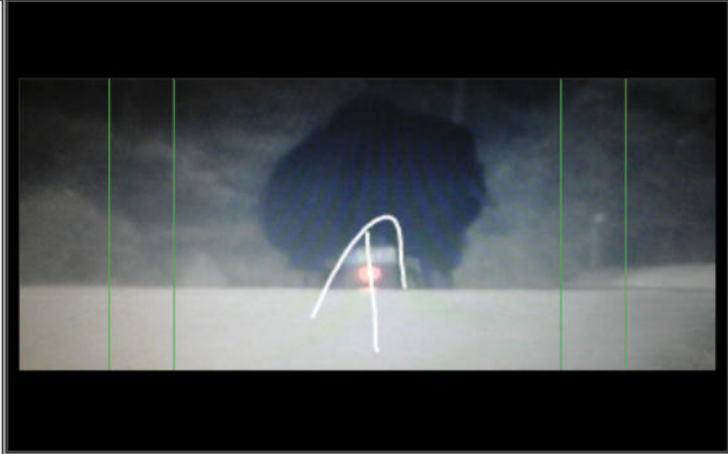

246

Sound/Dialog:

Sound: MUSIC

+ Motorcycle sound effect

Light Used:
 Lighting set;
 2x Arri Spot 500 W
 2 X Arri Spot 800 W
 2 X Arri Spot 1000 W
 2 X Arri Spot 2000 W
 Led Panel
 KinoFlo
 Soft box
 Lee lighting filter yellow and green
 Camera Tripod

91

Cast: Szabolcs Juhasz, and death costume Gábor Kis

45

173

Notes: Requesting a police roadblock for the duration of the shoot

60

Scene: Again on the road		Shooting Date: 8/10/2024
Shooting Place: Mártély City - road between all the Mindszent City.		Shooting Day: 2
Format: 2.39:1 Mode	Frame rate: 30P	Film Rating: ASA 200
Camera: SONY V1U	T-Stop: 3.5 Gain: 0 dB	Kelvin/Mired: 5600 /178.6
Lens: ZEISS DigiZoom Lenses 17-112mm T1.9	Shutter: 180 1/60	Studio Interior Exterior
Filter: No.	Focus: 1 meter	Dawn Day Dusk Night
Film Stock: 16:9 Mode HD	Camera Move: Fix camera shot	

Picture text:

PICTURE 27

Exterior - Mindszenti road – Late afternoon

The camera moves by the rider and his right hand is shown in close-up as he takes off the gas.

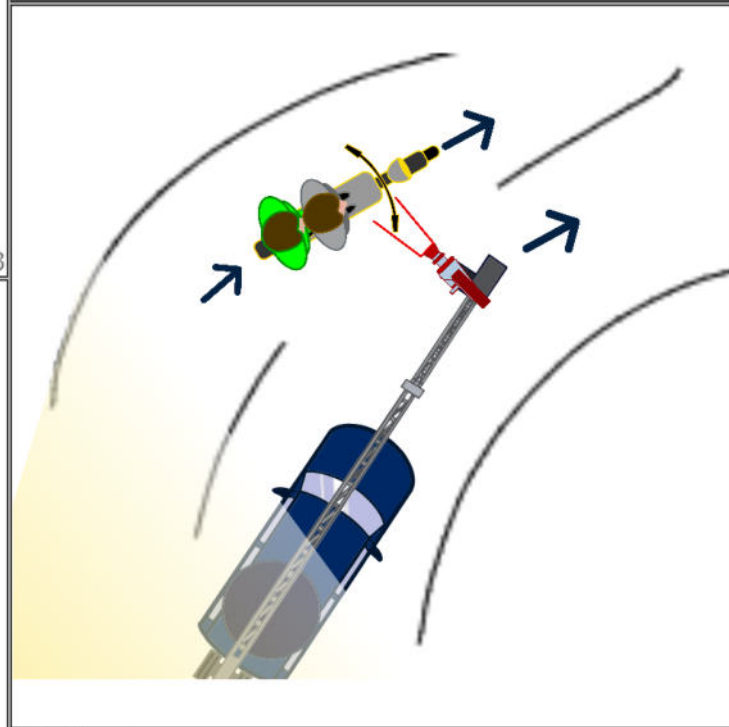

203

Sound/Dialog:

Sound: MUSIC

+ Motorcycle sound effect

Light Used:
 Lighting set;
 2x Arri Spot 500 W
 2 X Arri Spot 800 W
 2 X Arri Spot 1000 W
 2 X Arri Spot 2000 W
 Led Panel
 KinoFlo
 Soft box
 Lee lighting filter yellow and green
 Camera Tripod

91

Cast: Szabolcs Juhasz, and death costume Gábor Kis

45

173

Notes: Requesting a police roadblock for the duration of the shoot

60

Scene: Again on the road		Shooting Date: 8/10/2024
Shooting Place: Mártély City - road between all the Mindszent City.		Shooting Day: 2
Format: 2.39:1 Mode	Frame rate: 30P	Film Rating: ASA 200
Camera: SONY V1U	T-Stop: 4 Gain: 0 dB	Kelvin/Mired: 5600 /178.6
Lens: ZEISS DigiZoom Lenses 17-112mm T1.9	Shutter: 180 1/60	Studio Interior Exterior
Filter: No.	Focus: 0.30 meter	Dawn Day Dusk Night
Film Stock: 16:9 Mode HD	Camera Move: Fix camera shot	

Picture text:

PICTURE 28

Exterior - Mindszenti road – Late afternoon

The camera shows the image of the speedometer in a close-up going down under a hundred at a quite brisk rate.



224

Sound/Dialog:

Sound: MUSIC
+ Motorcycle sound effect

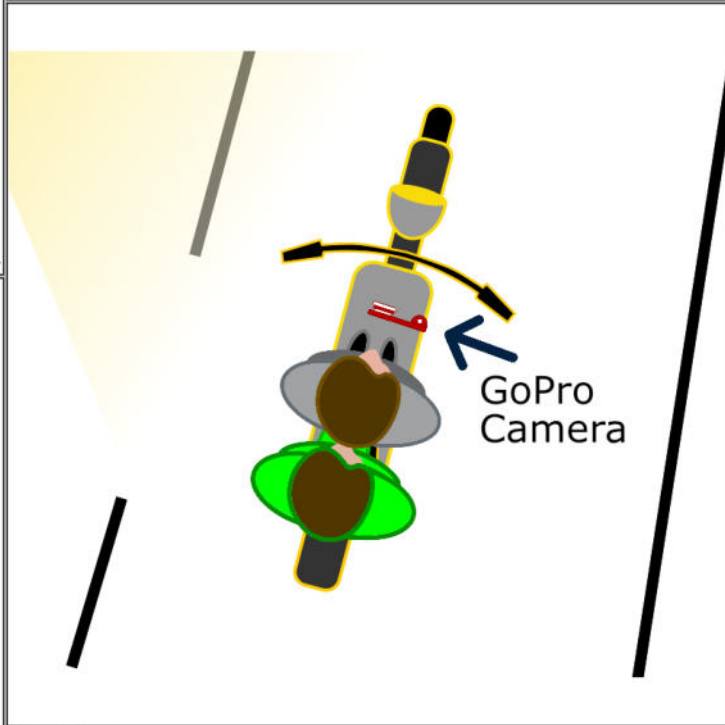

Light Used:
Lighting set;
2x Arri Spot 500 W
2 X Arri Spot 800 W
2 X Arri Spot 1000 W
2 X Arri Spot 2000 W
Led Panel
KinoFlo
Soft box
Lee lighting filter yellow and green
Camera Tripod

91

Cast: Szabolcs Juhasz, and death costume Gábor Kis

45

173

Notes: Requesting a police roadblock for the duration of the shoot

60

Scene: Again on the road		Shooting Date: 8/10/2024
Shooting Place: Mártély City - road between all the Mindszent City.		Shooting Day: 2
Format: 2.39:1 Mode	Frame rate: 30P	Film Rating: ASA 200
Camera: SONY V1U	T-Stop: 4 Gain: 0 dB	Kelvin/Mired: 5600 /178.6
Lens: ZEISS DigiZoom Lenses 17-112mm T1.9	Shutter: 180 1/60	Studio Interior Exterior
Filter: No.	Focus: 1 meter	Dawn Day Dusk Night
Film Stock: 16:9 Mode HD	Camera Move: Fix camera shot	

Picture text:

PICTURE 29

Exterior - Mindszenti road – Late afternoon

The camera moves when the engine and the front wheel of a marked slowdown in motor shows close-up.



214

Sound/Dialog:

Sound: MUSIC

+ Motorcycle sound effect

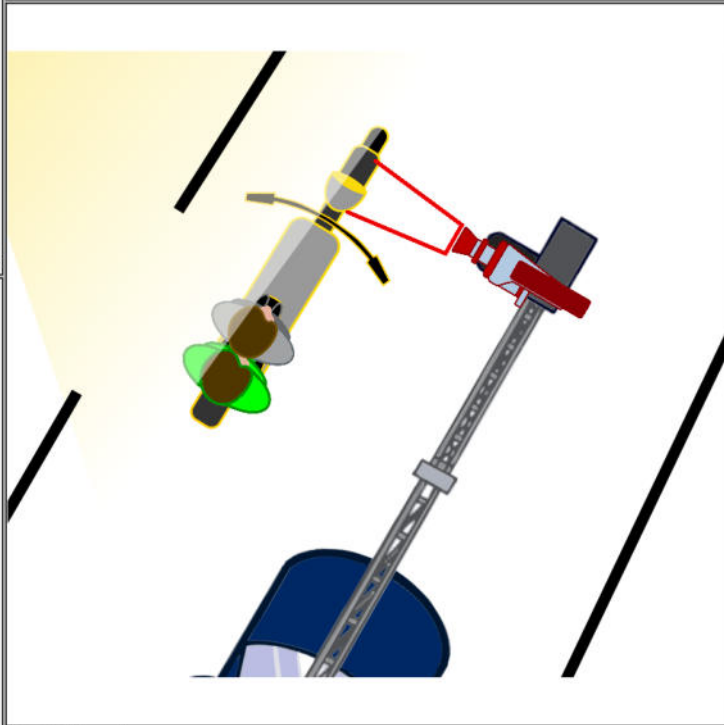

Light Used:
 Lighting set;
 2x Arri Spot 500 W
 2 X Arri Spot 800 W
 2 X Arri Spot 1000 W
 2 X Arri Spot 2000 W
 Led Panel
 KinoFlo
 Soft box
 Lee lighting filter yellow and green
 Camera Tripod

91

Cast: Szabolcs Juhasz, and death costume Gábor Kis

45

173

Notes: Requesting a police roadblock for the duration of the shoot

60

Scene: The new victim on the devil		Shooting Date: 8/10/2024
Shooting Place: Mártély City - road between all the Mindszent City.		Shooting Day: 2
Format: 2.39:1 Mode	Frame rate: 30P	Film Rating: ASA 200
Camera: SONY V1U	T-Stop: 2.8 Gain: 0 dB	Kelvin/Mired: 3200 /312.5
Lens: ZEISS DigiZoom Lenses 17-112mm T1.9	Shutter: 180 1/60	Studio Interior Exterior
Filter: No.	Focus: 1.8 meter	Dawn Day Dusk Night
Film Stock: 16:9 Mode HD	Camera Move: Fix camera shot, and zoom in	

Picture text:

PICTURE 35

Exterior - Mindszenti road - Evening

The camera is moving at a normal pace and the rolling wheels of the engine adapts, when suddenly from behind a motor speed bursts into the picture and drag it past him to sit behind him to death.



307

Sound/Dialog:

Sound: MUSIC

+ Motorcycle sound effect

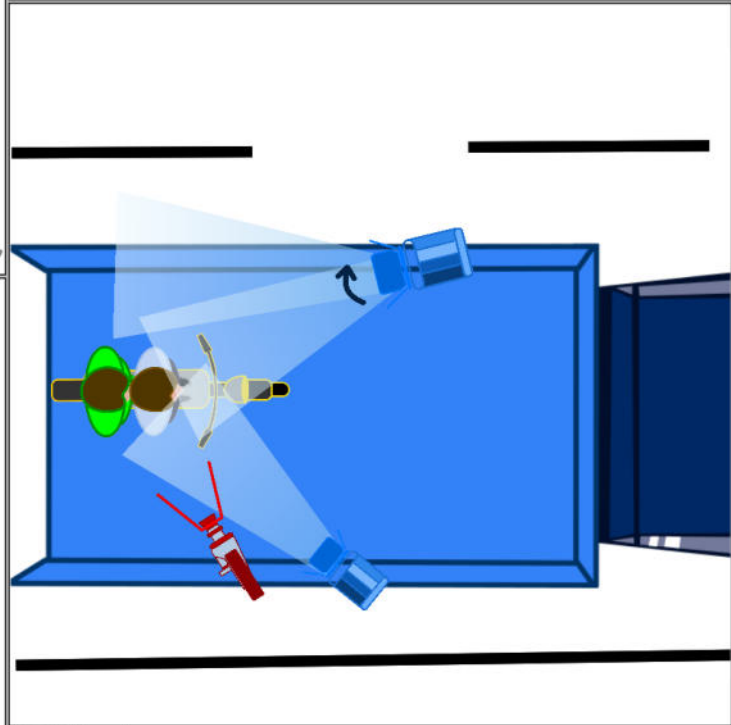

Light Used:
 Lighting set;
 2x Arri Spot 500 W
 2 X Arri Spot 800 W
 2 X Arri Spot 1000 W
 2 X Arri Spot 2000 W
 Led Panel
 KinoFlo
 Soft box
 Lee lighting filter yellow and green
 Camera Tripod

91

Cast: Speedmotor Ferenc Fekete, and death costume Gábor Kis

54

173

Notes: Requesting a police roadblock for the duration of the shoot

60

Scene: The new victim on the devil		Shooting Date: 8/10/2024
Shooting Place: Mártély City - road between all the Mindszent City.		Shooting Day: 2
Format: 2.39:1 Mode	Frame rate: 30P	Film Rating: ASA 200
Camera: SONY V1U	T-Stop: 2.8 Gain: 0 dB	Kelvin/Mired: 3200 /312.5
Lens: ZEISS DigiZoom Lenses 17-112mm T1.9	Shutter: 180 1/60	Studio Interior Exterior
Filter: No.	Focus: 0.30 meter	Dawn Day Dusk Night
Film Stock: 16:9 Mode HD	Camera Move: Fix camera shot and zoom in	

Picture text:

PICTURE 36

Exterior - Mindszenti road - Evening

The camera shows the Speedmotor engine speedometer on, as you go up, reaching the 200 km. and go over and moving on...

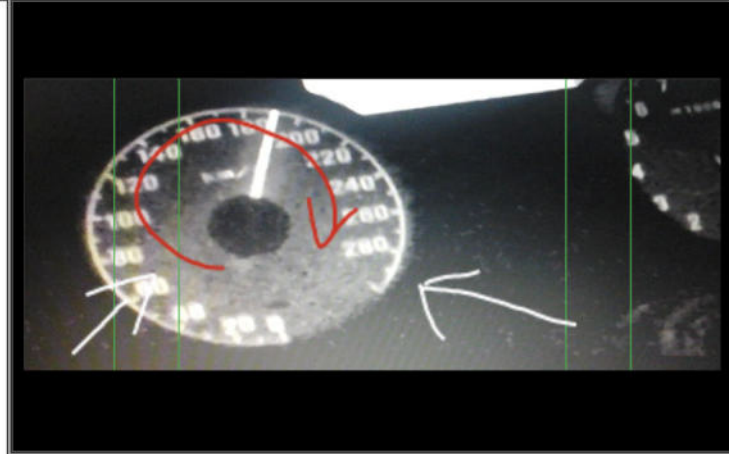

234

Sound/Dialog:

Sound: MUSIC
+ Motorcycle sound effect

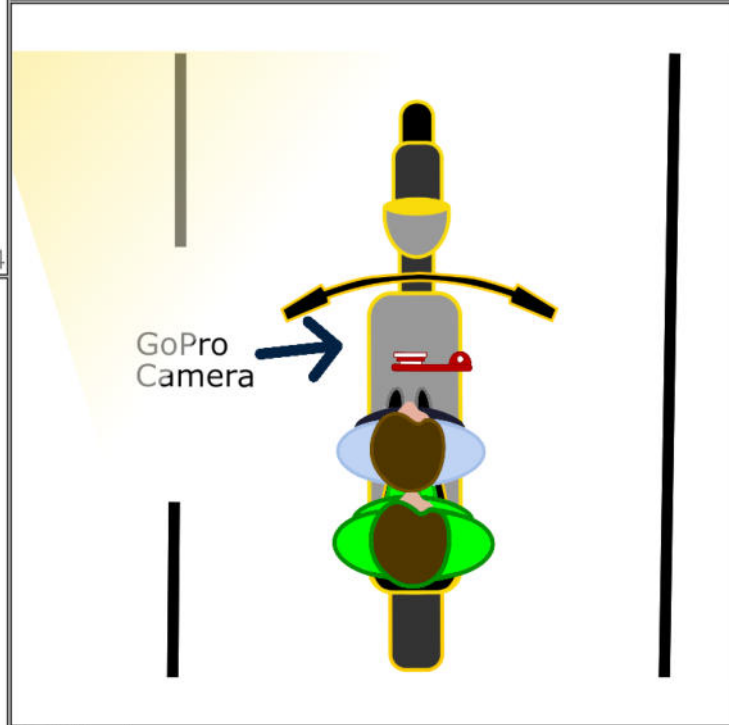

Light Used:
Lighting set;
2x Arri Spot 500 W
2 X Arri Spot 800 W
2 X Arri Spot 1000 W
2 X Arri Spot 2000 W
Led Panel
KinoFlo
Soft box
Lee lighting filter yellow and green
Camera Tripod

91

Cast: Speedmotor Ferenc Fekete, and death costume Gábor Kis

54

173

Notes: Requesting a police roadblock for the duration of the shoot

60

Scene: The new victim on the devil		Shooting Date: 8/10/2024
Shooting Place: Mártély City - road between all the Mindszent City.		Shooting Day: 2
Format: 2.39:1 Mode	Frame rate: 30P	Film Rating: ASA 200
Camera: SONY V1U	T-Stop: 3.2 Gain: 0 dB	Kelvin/Mired: 4000 /250
Lens: ZEISS DigiZoom Lenses 17-112mm T1.9	Shutter: 180 1/60	Studio Interior Exterior
Filter: No.	Focus: 30 meter	Dawn Day Dusk Night
Film Stock: 16:9 Mode HD	Camera Move: Fix camera shot	

Picture text:

PICTURE 37

Exterior - Mindszenti road - Evening

The camera shows the telephoto country road. From the left comes in a high-speed motor speed is sitting behind the Death on the road and drive as slowly disappearing at the bottom of the image. They go out of the picture. Here is sticking to the camera. They do not come into the picture from the bottom. The sun comes up. The title screen will be displayed.

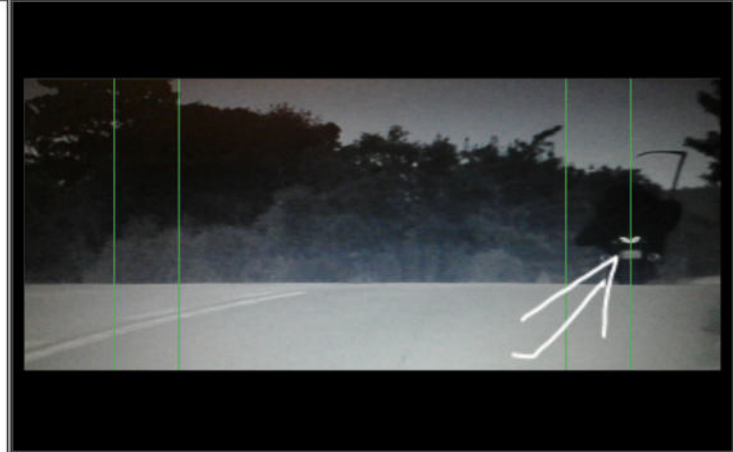

474

Sound/Dialog:

Sound: MUSIC
+ Motorcycle sound effect

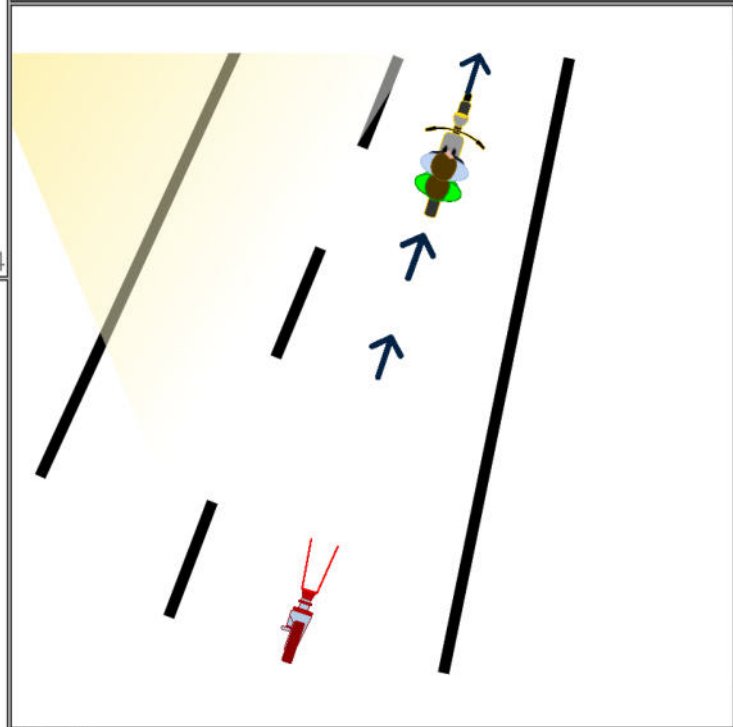

Light Used:
Lighting set;
2x Arri Spot 500 W
2 X Arri Spot 800 W
2 X Arri Spot 1000 W
2 X Arri Spot 2000 W
Led Panel
KinoFlo
Soft box
Lee lighting filter yellow and green
Camera Tripod

91

Cast: Speedmotor Ferenc Fekete, and death costume Gábor Kis

54

173

Notes: Requesting a police roadblock for the duration of the shoot

59

Scene: Waiting for a new victim		Shooting Date: 8/10/2024
Shooting Place: Mártély City - road between all the Mindszent City.		Shooting Day: 2
Format: 2.39:1 Mode	Frame rate: 30P	Film Rating: ASA 200
Camera: SONY V1U	T-Stop: 4 Gain: 0 dB	Kelvin/Mired: 3500 /285.7
Lens: ZEISS DigiZoom Lenses 17-112mm T1.9	Shutter: 180 1/60	Studio Interior Exterior
Filter: No.	Focus: 15 meter	Dawn Day Dusk Night
Film Stock: 16:9 Mode HD	Camera Move: Fix camera shot	

Picture text:

PICTURE 38

Exterior - Mindszenti road - Evening

Then we see standing on the roadside waiting for death as the next one.

182

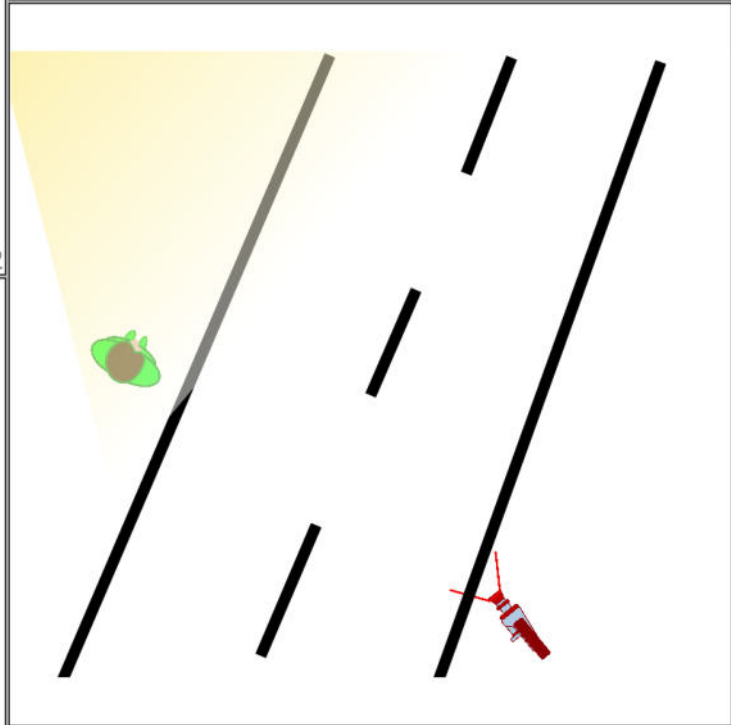

Sound/Dialog:

Sound: MUSIC

+ Motorcycle sound effect

91

Light Used:
 Lighting set;
 2x Arri Spot 500 W
 2 X Arri Spot 800 W
 2 X Arri Spot 1000 W
 2 X Arri Spot 2000 W
 Led Panel
 KinoFlo
 Soft box
 Lee lighting filter yellow and green
 Camera Tripod

Cast: The death costume Gábor Kis

28

173

Notes: Requesting a police roadblock for the duration of the shoot

60

Scene: One the road		Shooting Date: 8/11/2024
Shooting Place: Mártély City - road between all the Mindszent City.		Shooting Day: 3
Format: 2.39:1 Mode	Frame rate: 30P	Film Rating: ASA 200
Camera: SONY V1U	T-Stop: 5.6 Gain: 0 dB	Kelvin/Mired: 5600 /178.6
Lens: ZEISS DigiZoom Lenses 17-112mm T1.9	Shutter: 180 1/60	Studio Interior Exterior
Filter: No.	Focus: 2.5 meter	Dawn Day Dusk Night
Film Stock: 16:9 Mode HD	Camera Move: Camera tracks back, actor move	

Picture text:

PICTURE 13

Exterior - Mindszenti road - Afternoon

The camera shows -- in close-up medium plan -- from the front the rider as he is traveling on the highway. His eyes are visible through the face mask over his mouth. The Plexiglas visor is left open.



299

Sound/Dialog:

Sound: MUSIC
+ Motorcycle sound effect

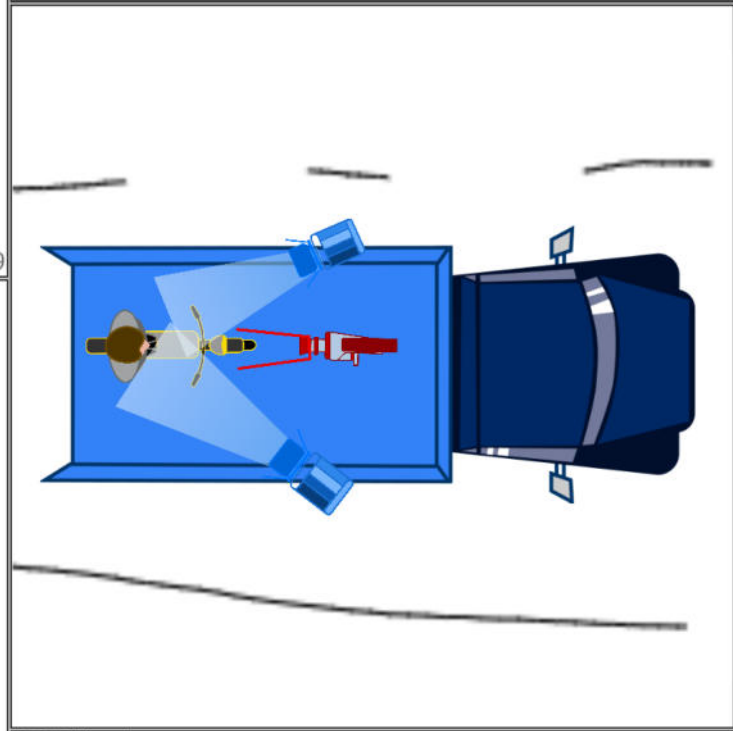

Light Used:
Lighting set;
2x Arri Spot 500 W
2 X Arri Spot 800 W
2 X Arri Spot 1000 W
2 X Arri Spot 2000 W
Led Panel
KinoFlo
Soft box
Lee lighting filter yellow and green
Camera Tripod

91

Cast: Szabolcs Juhasz

15

173

Notes: Requesting a police roadblock for the duration of the shoot

59

Scene: One the road		Shooting Date: 8/11/2024
Shooting Place: Mártély City - road between all the Mindszent City.		Shooting Day: 3
Format: 2.39:1 Mode	Frame rate: 30P	Film Rating: ASA 200
Camera: SONY V1U	T-Stop: 5.6 Gain: 0 dB	Kelvin/Mired: 5600 /178.6
Lens: ZEISS DigiZoom Lenses 17-112mm T1.9	Shutter: 180 1/60	Studio Interior Exterior
Filter: No.	Focus: 0.8 meter	Dawn Day Dusk Night
Film Stock: 16:9 Mode HD	Camera Move: Fix camera shot and zoom in	

Picture text:

PICTURES 15

Exterior - Mindszenti road - Afternoon

The camera shows the motorist JSZ side, close-up, as he enjoys the ride his expression changes, he recognizes the speed.



224

Sound/Dialog:

Sound: MUSIC
+ Motorcycle sound effect

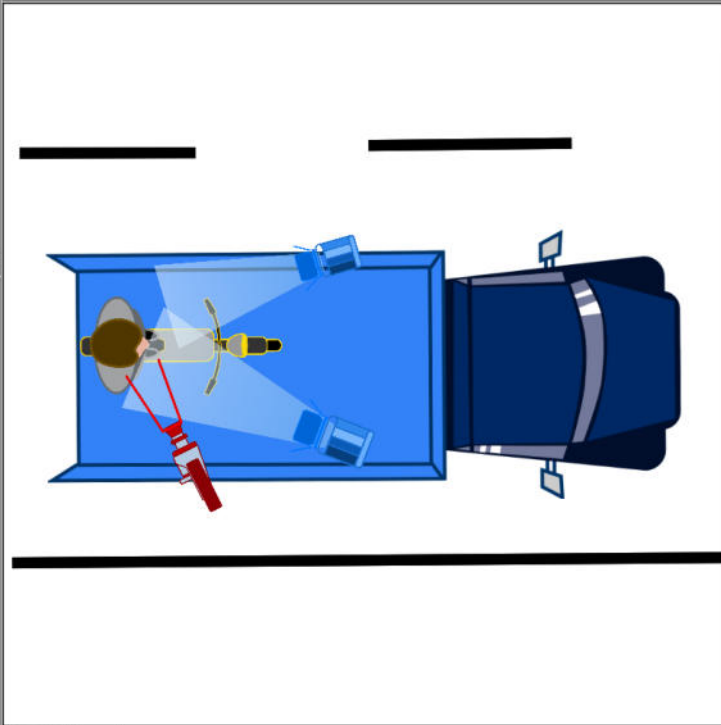

Light Used:
Lighting set;
2x Arri Spot 500 W
2 X Arri Spot 800 W
2 X Arri Spot 1000 W
2 X Arri Spot 2000 W
Led Panel
KinoFlo
Soft box
Lee lighting filter yellow and green
Camera Tripod

91

Cast: Szabolcs Juhasz

16

173

Notes: Requesting a police roadblock for the duration of the shoot

59

Scene: On the way with the devil		Shooting Date: 8/11/2024
Shooting Place: Mártély City - road between all the Mindszent City.		Shooting Day: 3
Format: 2.39:1 Mode	Frame rate: 30P	Film Rating: ASA 200
Camera: SONY V1U	T-Stop: 2.8 Gain: 0 dB	Kelvin/Mired: 3200 /312.5
Lens: ZEISS DigiZoom Lenses 17-112mm T1.9	Shutter: 180 1/60	Studio Interior Exterior
Filter: No.	Focus: 1.5 meter	Dawn Day Dusk Night
Film Stock: 16:9 Mode HD	Camera Move: Camera stays fixed, and zoom in	

Picture text:

PICTURE 19

Exterior - Mindszenti road - late afternoon

The camera shows again the rider's face super close, and then begins to open up medium close-up and from behind him death with the scythe is coming.

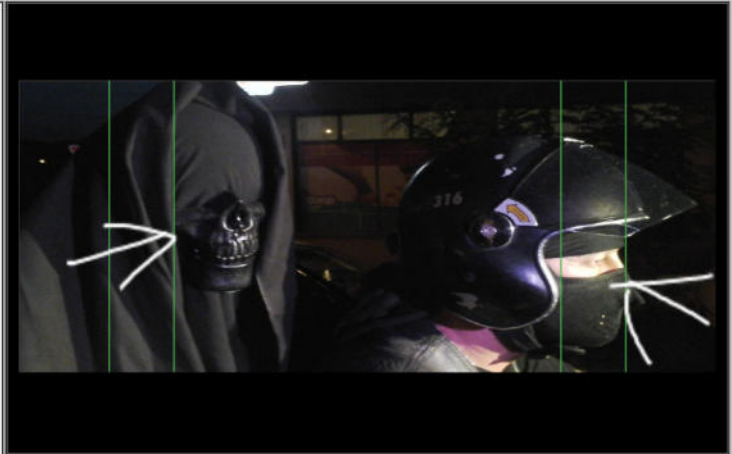

262

Sound/Dialog:

Sound: MUSIC

+ Motorcycle sound effect

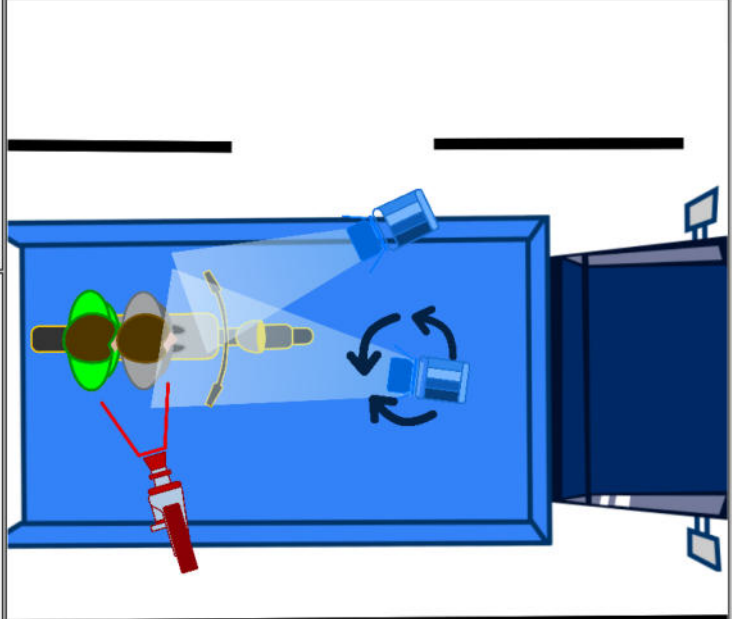

Light Used:
 Lighting set;
 2x Arri Spot 500 W
 2 X Arri Spot 800 W
 2 X Arri Spot 1000 W
 2 X Arri Spot 2000 W
 Led Panel
 KinoFlo
 Soft box
 Lee lighting filter yellow and green
 Camera Tripod

91

Cast: Szabolcs Juhasz, and death costume Gábor Kis

45

173

Notes: Requesting a police roadblock for the duration of the shoot

60

Scene: On the way with the devil		Shooting Date: 8/11/2024
Shooting Place: Mártély City - road between all the Mindszent City.		Shooting Day: 3
Format: 2.39:1 Mode	Frame rate: 30P	Film Rating: ASA 200
Camera: SONY V1U	T-Stop: 2.8 Gain: 0 dB	Kelvin/Mired: 3200 /312.5
Lens: ZEISS DigiZoom Lenses 17-112mm T1.9	Shutter: 180 1/60	Studio Interior Exterior
Filter: No.	Focus: 1.5 meter	Dawn Day Dusk Night
Film Stock: 16:9 Mode HD	Camera Move: Camera static, and zoom in	

Picture text:

PICTURE 21

Exterior - Mindszenti road – Late afternoon

The rider's face in close-up as he enjoys the speed. Death sits behind him.

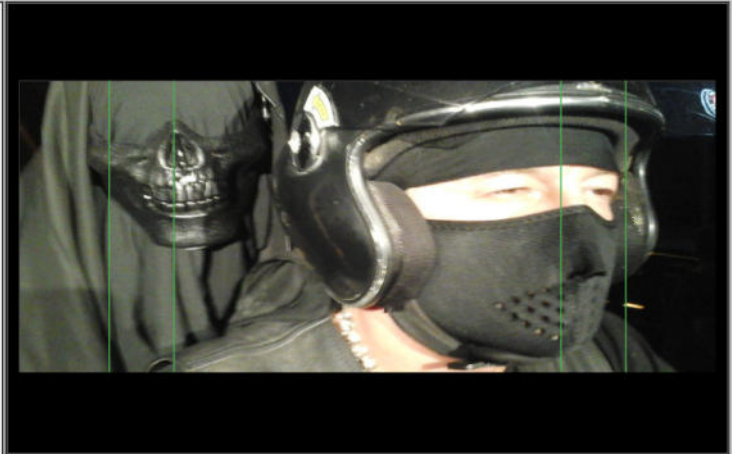

182

Sound/Dialog:

Sound: MUSIC

+ Motorcycle sound effect

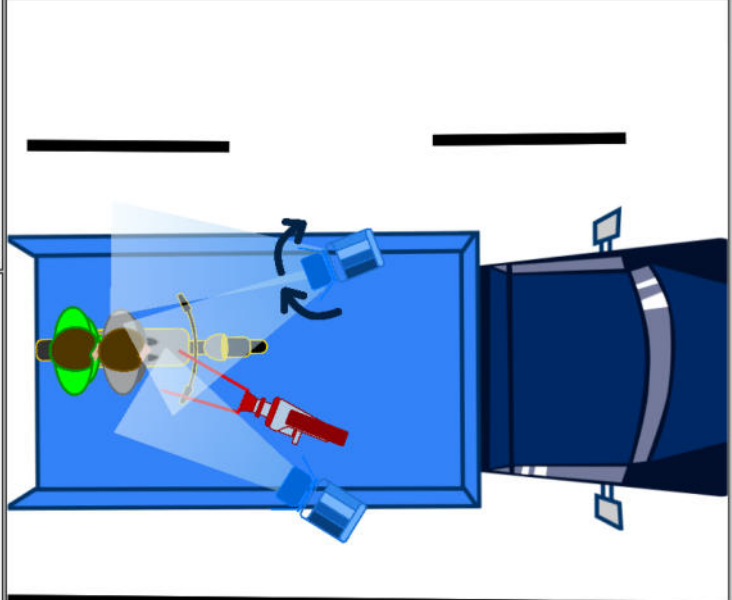

Light Used:
 Lighting set;
 2x Arri Spot 500 W
 2 X Arri Spot 800 W
 2 X Arri Spot 1000 W
 2 X Arri Spot 2000 W
 Led Panel
 KinoFlo
 Soft box
 Lee lighting filter yellow and green
 Camera Tripod

91

Cast: Szabolcs Juhasz, and death costume Gábor Kis

45

173

Notes: Requesting a police roadblock for the duration of the shoot

59

Scene: On the way with the devil		Shooting Date: 8/11/2024
Shooting Place: Mártély City - road between all the Mindszent City.		Shooting Day: 3
Format: 2.39:1 Mode	Frame rate: 30P	Film Rating: ASA 200
Camera: SONY V1U	T-Stop: 2.8 Gain: 0 dB	Kelvin/Mired: 4000 /250
Lens: ZEISS DigiZoom Lenses 17-112mm T1.9	Shutter: 180 1/60	Studio Interior Exterior
Filter: No.	Focus: 1.5 meter	Dawn Day Dusk Night
Film Stock: 16:9 Mode HD	Camera Move: Camera static, and zoom in	

Picture text:

PICTURE 24

Exterior - Mindszenti road – Late afternoon

The camera shows the front of the rider as death with his robe starts to cover him, growing medium plan, slow zoom face close-ups.



240

Sound/Dialog:

Sound: MUSIC

+ Motorcycle sound effect

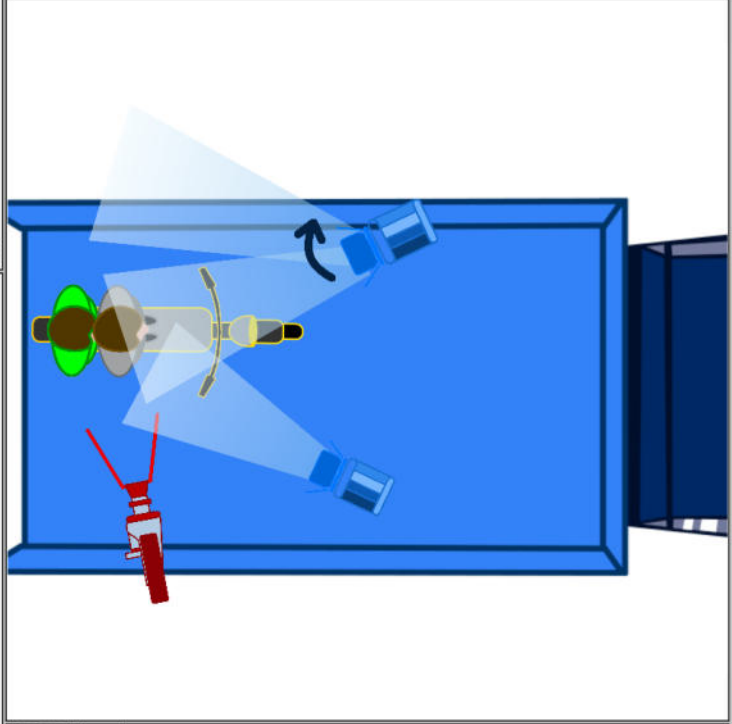

Light Used:
 Lighting set;
 2x Arri Spot 500 W
 2 X Arri Spot 800 W
 2 X Arri Spot 1000 W
 2 X Arri Spot 2000 W
 Led Panel
 KinoFlo
 Soft box
 Lee lighting filter yellow and green
 Camera Tripod

91

Cast: Szabolcs Juhasz, and death costume Gábor Kis

45

173

Notes: Requesting a police roadblock for the duration of the shoot

59

Scene: On the way with the devil		Shooting Date: 8/11/2024
Shooting Place: Mártély City - road between all the Mindszent City.		Shooting Day: 3
Format: 2.39:1 Mode	Frame rate: 30P	Film Rating: ASA 200
Camera: SONY V1U	T-Stop: 2.8 Gain: 0 dB	Kelvin/Mired: 4000 /250
Lens: ZEISS DigiZoom Lenses 17-112mm T1.9	Shutter: 180 1/60	Studio Interior Exterior
Filter: No.	Focus: 1.5 meter	Dawn Day Dusk Night
Film Stock: 16:9 Mode HD	Camera Move: Camera static, and zoom out	

Picture text:

PICTURE 26

Exterior - Mindszenti road – Late afternoon

The camera shows close-up side to the motor slight zoom on the fly, as he leans forward to death. Close up super close to the end when a slight smile appears on the motorists his face.



298

Sound/Dialog:

Sound: MUSIC
+ Motorcycle sound effect

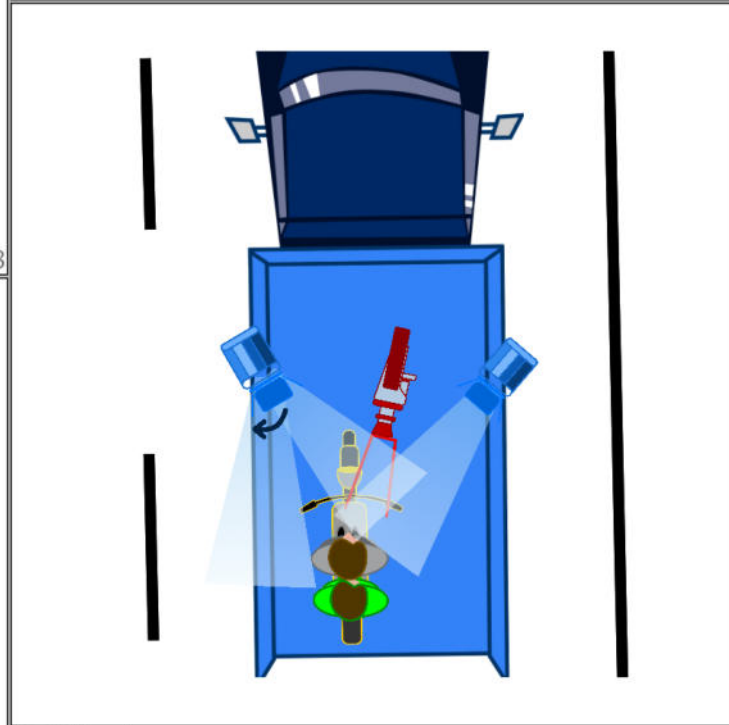

Light Used:
Lighting set;
2x Arri Spot 500 W
2 X Arri Spot 800 W
2 X Arri Spot 1000 W
2 X Arri Spot 2000 W
Led Panel
KinoFlo
Soft box
Lee lighting filter yellow and green
Camera Tripod

91

Cast: Szabolcs Juhasz, and death costume Gábor Kis

45

173

Notes: Requesting a police roadblock for the duration of the shoot

60

Scene: One the road		Shooting Date: 8/12/2024
Shooting Place: Mártély City - road between all the Mindszent City.		Shooting Day: 4
Format: 2.39:1 Mode	Frame rate: 30P	Film Rating: ASA 200
Camera: SONY V1U	T-Stop: 5.6 Gain: 0 dB	Kelvin/Mired: 5600 /178.6
Lens: ZEISS DigiZoom Lenses 17-112mm T1.9	Shutter: 180 1/60	Studio Interior Exterior
Filter: No.	Focus: 4 meter	Dawn Day Dusk Night
Film Stock: 16:9 Mode HD	Camera Move: Camera stays fixed	

Picture text:

PICTURE 14

Exterior - Mindszenti road - Afternoon

The camera shows from the side of the road in American Plan as he is driving on the highway, the camera in panorama follows him from left to right.

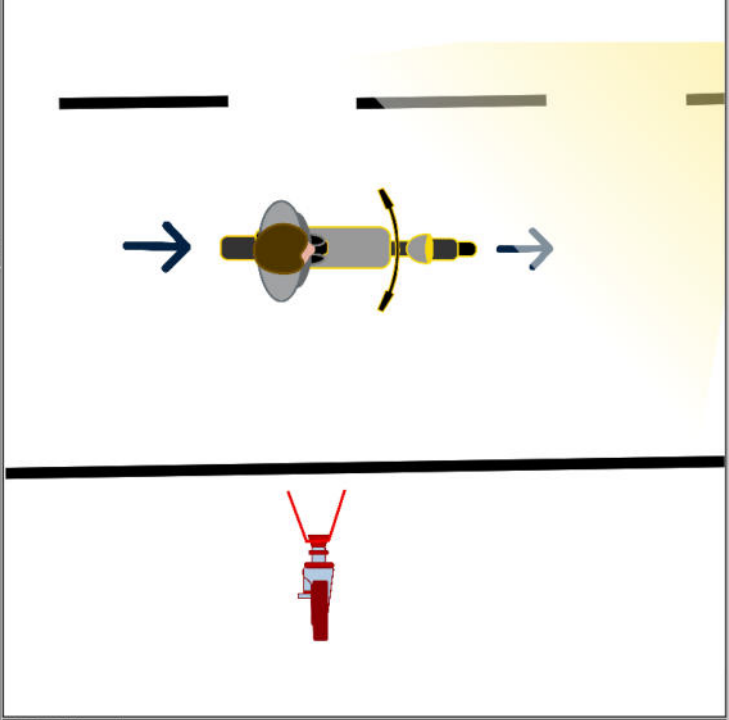

Sound/Dialog:

Sound: MUSIC

+ Motorcycle sound effect

Light Used:
 Lighting set;
 2x Arri Spot 500 W
 2 X Arri Spot 800 W
 2 X Arri Spot 1000 W
 2 X Arri Spot 2000 W
 Led Panel
 KinoFlo
 Soft box
 Lee lighting filter yellow and green
 Camera Tripod

Cast: Szabolcs Juhasz

Notes: Requesting a police roadblock for the duration of the shoot

Scene: One the road		Shooting Date: 8/12/2024
Shooting Place: Mártély City - road between all the Mindszent City.		Shooting Day: 4
Format: 2.39:1 Mode	Frame rate: 30P	Film Rating: ASA 200
Camera: SONY V1U	T-Stop: 5.6 Gain: 0 dB	Kelvin/Mired: 5600 /178.6
Lens: ZEISS DigiZoom Lenses 17-112mm T1.9	Shutter: 180 1/60	Studio Interior Exterior
Filter: No.	Focus: 5 meter	Dawn Day Dusk Night
Film Stock: 16:9 Mode HD	Camera Move: Camera stays fixed	

Picture text:

PICTURE 17

Exterior - Mindszenti road – Late afternoon

The camera is put down on the road, speeding away next to it the Harley engine at high speed. Fixed Plan.

213



Sound/Dialog:

Sound: MUSIC

+ Motorcycle sound effect

91

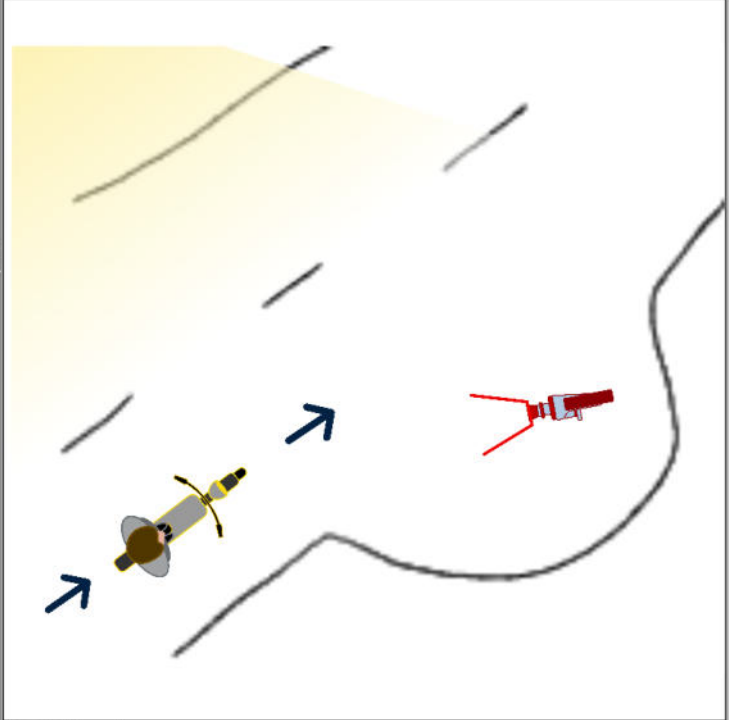

Light Used:
 Lighting set;
 2x Arri Spot 500 W
 2 X Arri Spot 800 W
 2 X Arri Spot 1000 W
 2 X Arri Spot 2000 W
 Led Panel
 KinoFlo
 Soft box
 Lee lighting filter yellow and green
 Camera Tripod

173

Cast: Szabolcs Juhasz

15

Notes: Requesting a police roadblock for the duration of the shoot

60

Scene: On the way with the devil		Shooting Date: 8/12/2024
Shooting Place: Mártély City - road between all the Mindszent City.		Shooting Day: 4
Format: 2.39:1 Mode	Frame rate: 30P	Film Rating: ASA 200
Camera: SONY V1U	T-Stop: 3.2 Gain: 0 dB	Kelvin/Mired: 4000 /250
Lens: ZEISS DigiZoom Lenses 17-112mm T1.9	Shutter: 180 1/60	Studio Interior Exterior
Filter: No.	Focus: 18 meter	Dawn Day Dusk Night
Film Stock: 16:9 Mode HD	Camera Move: Camera pans right	

Picture text:

PICTURE 23

Exterior - Mindszenti road – Late afternoon

The camera is standing by the road-side (fixed plan) and the motor is speeding past him, behind him is Death who increasingly obscures the rider.

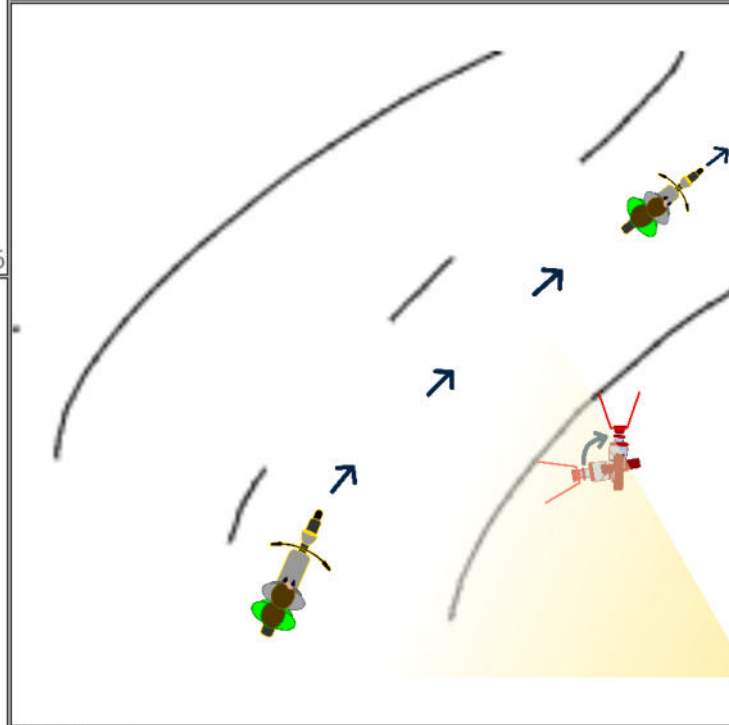
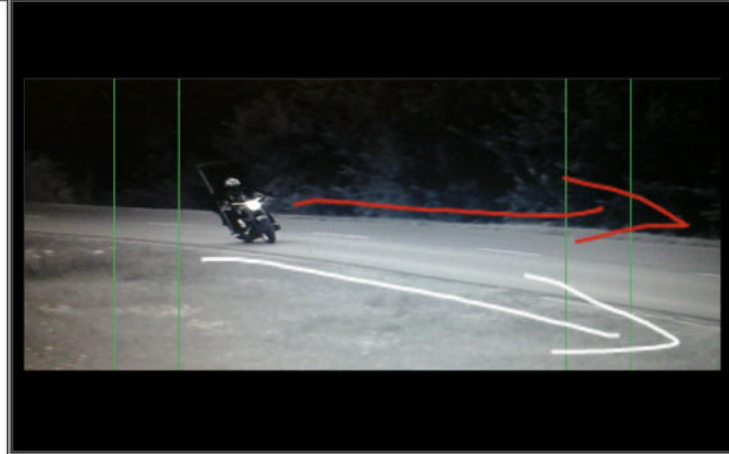

256

Sound/Dialog:

Sound: MUSIC

+ Motorcycle sound effect

Light Used:
 Lighting set;
 2x Arri Spot 500 W
 2 X Arri Spot 800 W
 2 X Arri Spot 1000 W
 2 X Arri Spot 2000 W
 Led Panel
 KinoFlo
 Soft box
 Lee lighting filter yellow and green
 Camera Tripod

91

Cast: Szabolcs Juhasz, and death costume Gábor Kis

45

173

Notes: Requesting a police roadblock for the duration of the shoot

59

Scene: On the way with the devil		Shooting Date: 8/12/2024
Shooting Place: Mártély City - road between all the Mindszent City.		Shooting Day: 4
Format: 2.39:1 Mode	Frame rate: 30P	Film Rating: ASA 200
Camera: SONY V1U	T-Stop: 4 Gain: 0 dB	Kelvin/Mired: 4000 /250
Lens: ZEISS DigiZoom Lenses 17-112mm T1.9	Shutter: 180 1/60	Studio Interior Exterior
Filter: No.	Focus: 1.2 meter	Dawn Day Dusk Night
Film Stock: 16:9 Mode HD	Camera Move: Camera follows the motorcycle	

Picture text:

PICTURE 25

Exterior - Mindszenti road – Late afternoon

The camera is in the bend in the direction of Mindszent. The Harley comes into the picture from the left with death behind him, and as the road is rising and then steadily going out of the picture, thereafter at the bottom of the picture disappears completely.



370

Sound/Dialog:

Sound: MUSIC
+ Motorcycle sound effect

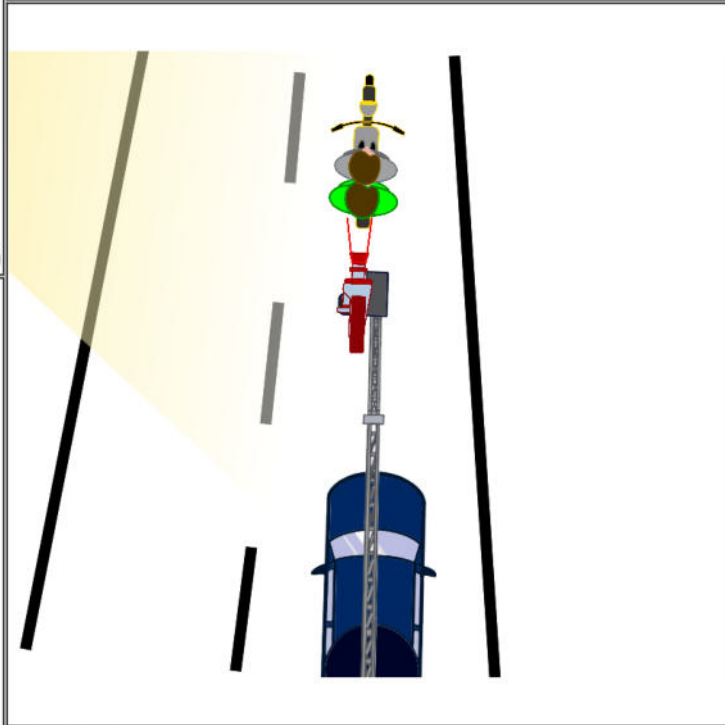

Light Used:
Lighting set;
2x Arri Spot 500 W
2 X Arri Spot 800 W
2 X Arri Spot 1000 W
2 X Arri Spot 2000 W
Led Panel
KinoFlo
Soft box
Lee lighting filter yellow and green
Camera Tripod

91

Cast: Szabolcs Juhasz, and death costume Gábor Kis

45

173

Notes: Requesting a police roadblock for the duration of the shoot

59

Scene: Again on the road		Shooting Date: 8/12/2024
Shooting Place: Mártély City - road between all the Mindszent City.		Shooting Day: 4
Format: 2.39:1 Mode	Frame rate: 30P	Film Rating: ASA 200
Camera: SONY V1U	T-Stop: 5.6 Gain: 0 dB	Kelvin/Mired: 5600 /178.6
Lens: ZEISS DigiZoom Lenses 17-112mm T1.9	Shutter: 180 1/60	Studio Interior Exterior
Filter: No.	Focus: 12 meter	Dawn Day Dusk Night
Film Stock: 16:9 Mode HD	Camera Move: Fix camera shot	

Picture text:

PICTURE 30

Exterior - Mindszenti road – Late afternoon

The camera is in the bend of the road towards the city. The 25 camera plan, as the road emerges from the bottom of the picture and death is no longer behind the motorist.

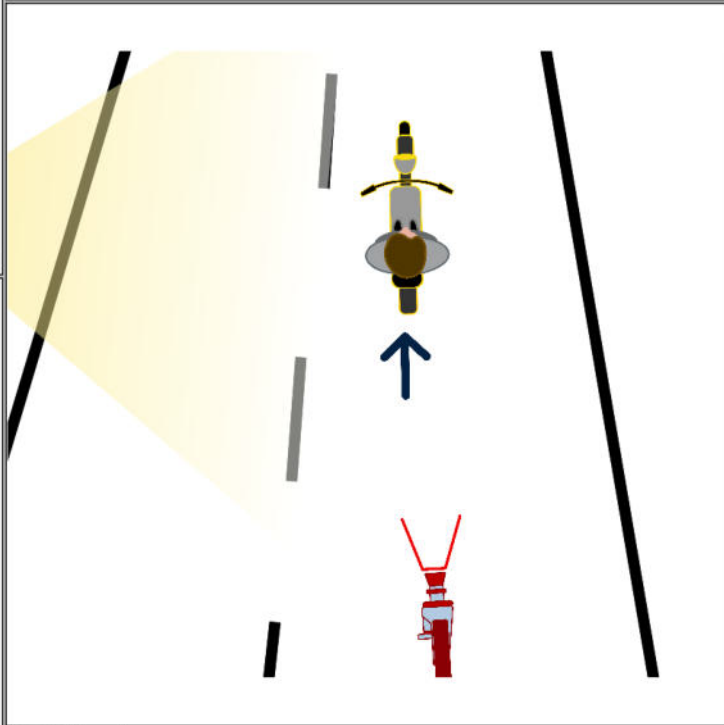
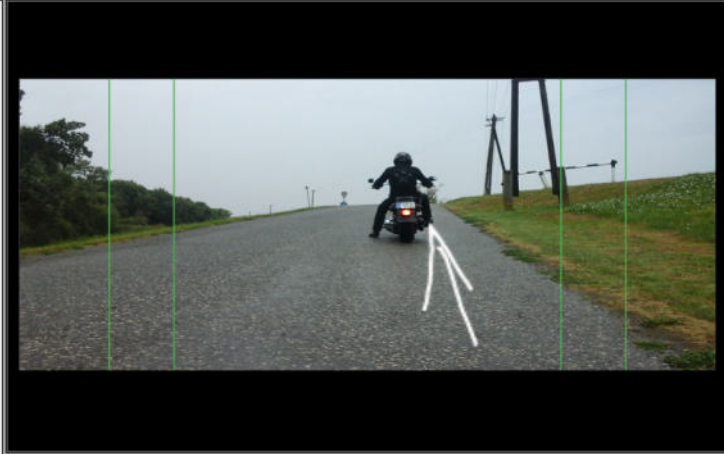

291

Sound/Dialog:

Sound: MUSIC
+ Motorcycle sound effect

Light Used:
Lighting set;
2x Arri Spot 500 W
2 X Arri Spot 800 W
2 X Arri Spot 1000 W
2 X Arri Spot 2000 W
Led Panel
KinoFlo
Soft box
Lee lighting filter yellow and green
Camera Tripod

91

Cast: Szabolcs Juhasz, and death costume Gábor Kis

45

173

Notes: Requesting a police roadblock for the duration of the shoot

60

Scene: Again on the road		Shooting Date: 8/12/2024
Shooting Place: Mártély City - road between all the Mindszent City.		Shooting Day: 4
Format: 2.39:1 Mode	Frame rate: 30P	Film Rating: ASA 200
Camera: SONY V1U	T-Stop: 4.5 Gain: 0 dB	Kelvin/Mired: 5600 /178.6
Lens: ZEISS DigiZoom Lenses 17-112mm T1.9	Shutter: 180 1/60	Studio Interior Exterior
Filter: No.	Focus: 4 meter	Dawn Day Dusk Night
Film Stock: 16:9 Mode HD	Camera Move: Camera static, follows actor	

Picture text:

PICTURE 31

Exterior - Mindszenti road – Late afternoon

The camera is the lower machine shows the position of the rider as telephoto comes in and mop up the uphill road, behind it there is no death. The motorcycle crossed the road turns to the left side of the road and stop and look back. The death enters the picture from the left to the hands of the scythe, felt the distance between them.

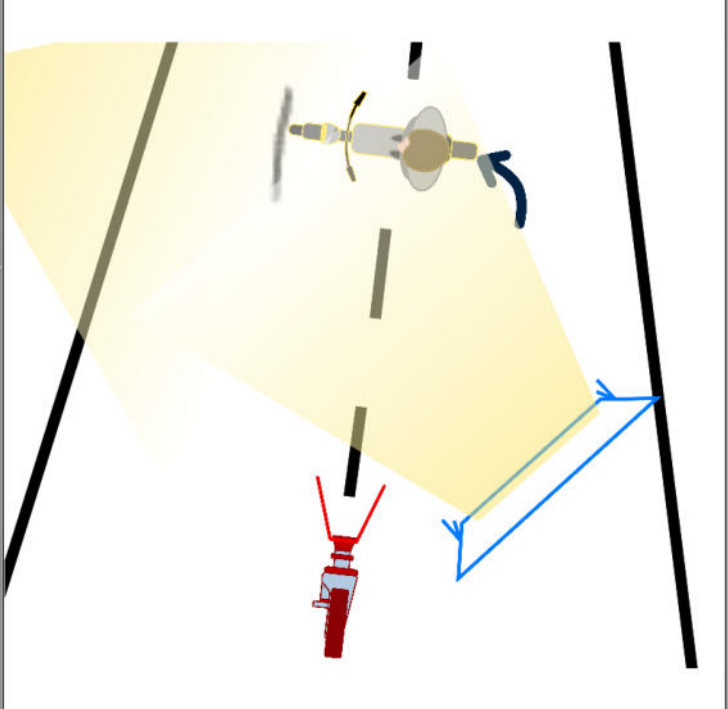

Sound/Dialog:

Sound: MUSIC

+ Motorcycle sound effect

Light Used:
 Lighting set;
 2x Arri Spot 500 W
 2 X Arri Spot 800 W
 2 X Arri Spot 1000 W
 2 X Arri Spot 2000 W
 Led Panel
 KinoFlo
 Soft box
 Lee lighting filter yellow and green
 Camera Tripod

Cast: Szabolcs Juhasz, and death costume Gábor Kis

Notes: Requesting a police roadblock for the duration of the shoot

Scene: Again on the road		Shooting Date: 8/12/2024
Shooting Place: Mártély City - road between all the Mindszent City.		Shooting Day: 4
Format: 2.39:1 Mode	Frame rate: 30P	Film Rating: ASA 200
Camera: SONY V1U	T-Stop: 5.6 Gain: 0 dB	Kelvin/Mired: 5600 /178.6
Lens: ZEISS DigiZoom Lenses 17-112mm T1.9	Shutter: 180 1/60	Studio Interior Exterior
Filter: No.	Focus: 12 meter	Dawn Day Dusk Night
Film Stock: 16:9 Mode HD	Camera Move: Camera static, follows actor	

Picture text:

PICTURE 32

Exterior - Mindszenti road – Late afternoon

When you come up with the rider rising to the top and stops and looks back close-up picture. 32 / B. medium total.

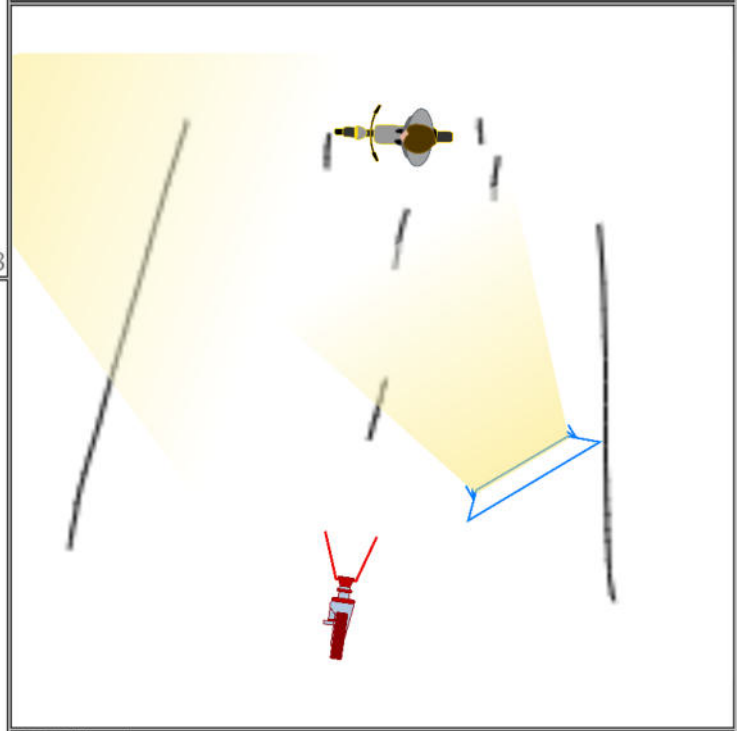
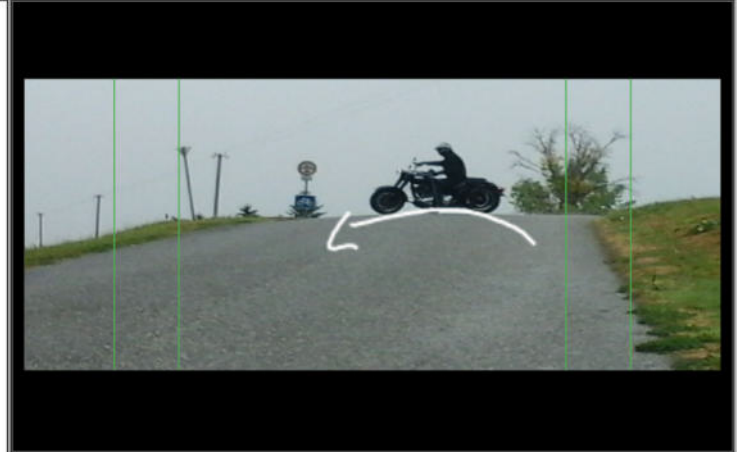

Sound/Dialog:

Sound: MUSIC

+ Motorcycle sound effect

Light Used:
 Lighting set;
 2x Arri Spot 500 W
 2 X Arri Spot 800 W
 2 X Arri Spot 1000 W
 2 X Arri Spot 2000 W
 Led Panel
 KinoFlo
 Soft box
 Lee lighting filter yellow and green
 Camera Tripod

Cast: Szabolcs Juhasz, and death costume Gábor Kis

Notes: Requesting a police roadblock for the duration of the shoot

Scene: Again on the road		Shooting Date: 8/12/2024
Shooting Place: Mártély City - road between all the Mindszent City.		Shooting Day: 4
Format: 2.39:1 Mode	Frame rate: 30P	Film Rating: ASA 200
Camera: SONY V1U	T-Stop: 3.5 Gain: 0 dB	Kelvin/Mired: 5600 /178.6
Lens: ZEISS DigiZoom Lenses 17-112mm T1.9	Shutter: 180 1/60	Studio Interior Exterior
Filter: No.	Focus: 0.8 meter	Dawn Day Dusk Night
Film Stock: 16:9 Mode HD	Camera Move: Fix camera shot	

Picture text:

PICTURE 33

Exterior - Mindszenti road – Late afternoon

The nearby Close up of the concrete road, when death enters the picture and the cloak hangs end of the scythe to the ground.

247

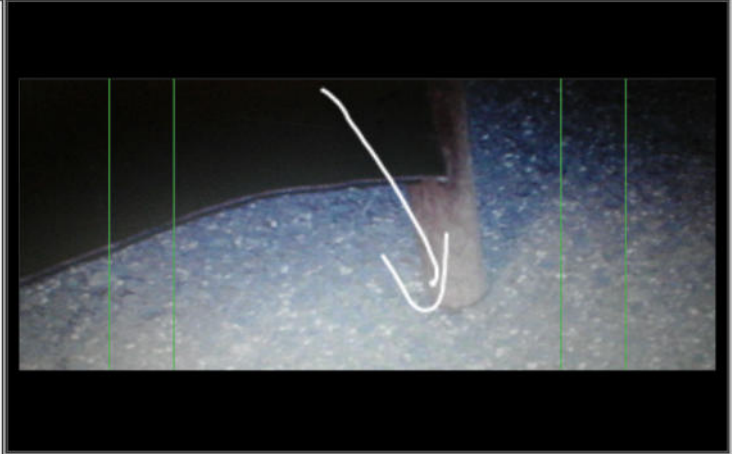

Sound/Dialog:

Sound: MUSIC

+ Motorcycle sound effect

91

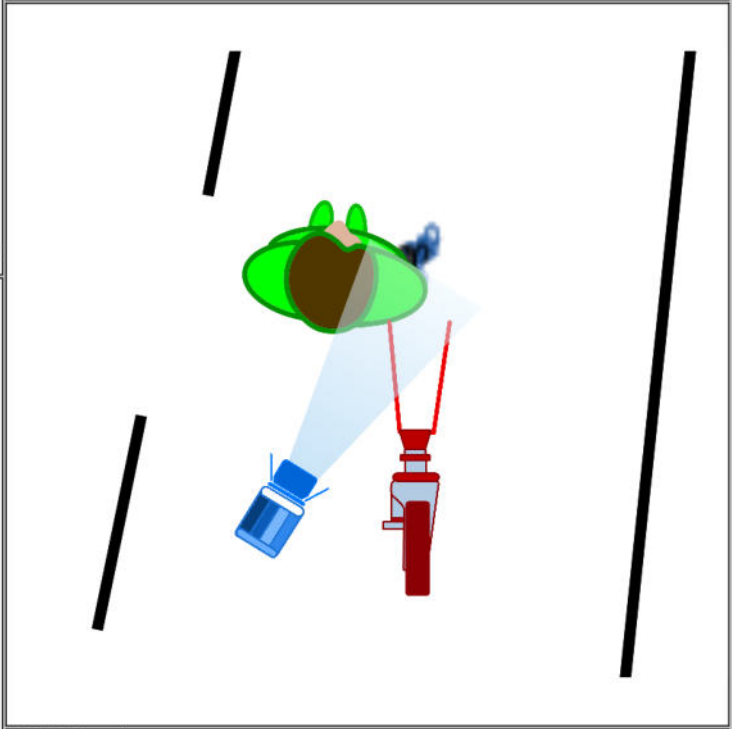

Light Used:
 Lighting set;
 2x Arri Spot 500 W
 2 X Arri Spot 800 W
 2 X Arri Spot 1000 W
 2 X Arri Spot 2000 W
 Led Panel
 KinoFlo
 Soft box
 Lee lighting filter yellow and green
 Camera Tripod

173

Cast: Szabolcs Juhasz, and death costume Gábor Kis

45

Notes: Requesting a police roadblock for the duration of the shoot

60

Scene: Again on the road		Shooting Date: 8/12/2024
Shooting Place: Mártély City - road between all the Mindszent City.		Shooting Day: 4
Format: 2.39:1 Mode	Frame rate: 30P	Film Rating: ASA 200
Camera: SONY V1U	T-Stop: 4.5 Gain: 0 dB	Kelvin/Mired: 5600 /178.6
Lens: ZEISS DigiZoom Lenses 17-112mm T1.9	Shutter: 180 1/60	Studio Interior Exterior
Filter: No.	Focus: 10 meter	Dawn Day Dusk Night
Film Stock: 16:9 Mode HD	Camera Move: Fix camera shot	

Picture text:

PICTURE 34

Exterior - Mindszenti road – Late afternoon

The camera (31.es Close up) illustrates the rider as telephoto turn left but continued his journey begins more relaxed pace, leaving about death. The picture on the left edge picture on the mantle of death.

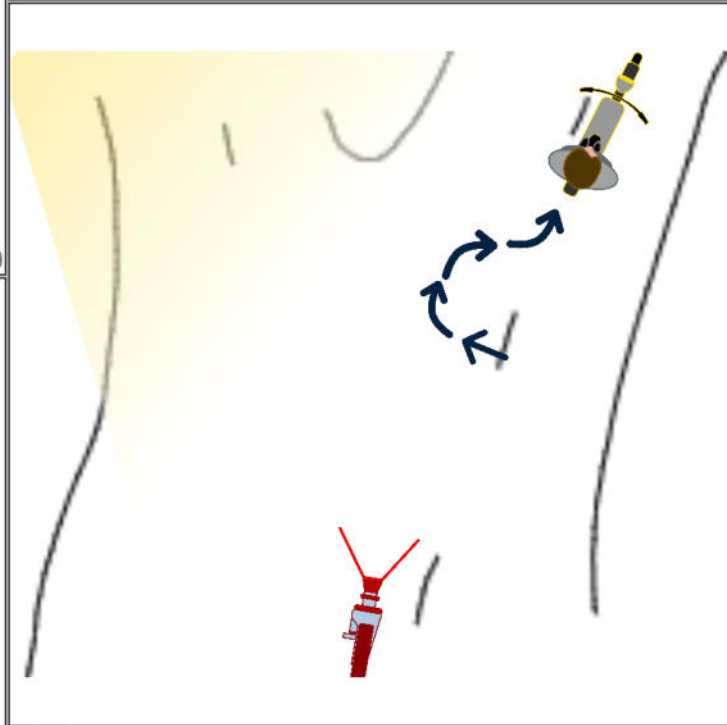

320

Sound/Dialog:

Sound: MUSIC

+ Motorcycle sound effect

Light Used:
 Lighting set;
 2x Arri Spot 500 W
 2 X Arri Spot 800 W
 2 X Arri Spot 1000 W
 2 X Arri Spot 2000 W
 Led Panel
 KinoFlo
 Soft box
 Lee lighting filter yellow and green
 Camera Tripod

91

Cast: Szabolcs Juhasz, and death costume Gábor Kis

45

173

Notes: Requesting a police roadblock for the duration of the shoot

60